

# Original User Manual

## Series Touch Industrial PC



Christ Electronic Systems GmbH

Alpenstraße 34

87700 Memmingen

06/2023

[www.christ-es.com](http://www.christ-es.com)

# Instruction Manual: Touch Industrial PC

<b>1</b>	<b>Identification</b>	<b>4</b>
<b>2</b>	<b>Product description</b>	<b>7</b>
2.1	System Overview	8
2.2	Housing Variant VESA	9
2.3	Housing Variant VESA Automation	12
2.4	Housing variant Front Panel	20
2.5	Housing Variant Open Frame	22
<b>3</b>	<b>Description Hardware</b>	<b>26</b>
3.1	External Interfaces	26
3.2	Add-On	32
3.2.1	UPS (Uninterruptible Power Supply)	32
3.2.2	Add On Interface Main Device	32
3.2.3	Add On Interface Side	33
<b>4</b>	<b>Mounting</b>	<b>34</b>
4.1	Torque	34
4.2	Connection of the power supply	35
4.3	Earth Connection	35
4.4	Mounting VESA and VESA Automation	36
4.5	Mounting Front Panel	39
4.6	Mounting Open Frame	40
4.7	Faceplate	41
4.7.1	Dismounting faceplate	41
4.7.2	Adjusting the faceplate	42
4.7.3	Pushbutton boards	43
4.7.4	Mounting faceplate	43
<b>5</b>	<b>Commissioning</b>	<b>45</b>
5.1	Function of the power button	45
5.2	Unusual situations	45
5.2.1	Undefined state during start-up process	45
5.2.2	Sluggish touch behavior	46
<b>6</b>	<b>Accessories and Spare Parts</b>	<b>47</b>
6.1	Power supply	47
6.2	Stand	47

# Instruction Manual: Touch Industrial PC

<b>7</b>	<b>Software</b>	<b>48</b>
7.1	BIOS Basic Settings	48
7.1.1	Set display resolution	49
7.1.2	COM Port configuration	49
7.1.3	Set Boot Priority	50
7.2	BIOS Update	52
7.2.1	Preparation	52
7.2.2	Perform Update	52
7.3	OBS Client	54
7.3.1	Activating the OBS Client	54
7.3.2	Functions of the OBS Client	54
7.4	Redo Backup and Recovery	55
7.5	Enhanced Write Filter EWF	55
<b>8</b>	<b>Maintenance</b>	<b>56</b>
8.1	Cleaning	56
8.2	Maintenance	56
<b>9</b>	<b>Technical Data</b>	<b>57</b>
9.1	Mechanical Specifications	57
9.2	Electrical Specifications	57
9.3	Power Consumption	58
9.4	Electromagnetic Compatibility	58
9.5	Environmental Conditions	59
9.6	Temperature test	59
9.7	IP Protection Class	59
9.8	Display Specifications	60
<b>10</b>	<b>Standards and Approvals</b>	<b>62</b>
10.1	CE Marking	62
10.2	RoHS	62
10.3	Electromagnetic Compatibility	62
10.4	Environmentally Appropriate Disposal	62
<b>11</b>	<b>Technical Support</b>	<b>63</b>
11.1	Device Seal	63

# Instruction Manual: Touch Industrial PC

## 1 Identification

### Target group

This document is not intended for end customers! Necessary safety instructions for the end customer must be passed on by the machine builder or system provider and adopted in the respective national language.

### Intended use

The devices described in this documentation are intended to enable the user to control, operate, observe, drive and visualise certain processes.

### Technical changes

Christ Electronic Systems GmbH reserves the right to change the information, designs and technical data contained in this documentation without prior notice.

### History

The following editions of the manual have already been published:

Version	Comment
05/2021 Rev. 00	First edition
04/2022 Rev. 01	Avoid burn-in on displays UPS buffer duration Improvement: VESA 100 instead of VESA 75 with VESA Automation IP65 Integration of size 15" and 24" Dimensions updated
02/2023 Rev. 02	Revision Identification Revision of the design of safety instructions Power Consumption updated Weight specifications updated Current capacity VESA Automation Electrical specifications updated Components VESA Automation updated Integration of size 10.4" Integration of housing variant Open Frame
04/2023 Rev. 03	Chapter 2.3 Housing Variant VESA Automation: Revision of components Pushbuttons, Emergency Stop, RFID Chapter 3.1 External Interfaces: Notice signal and data cables included Chapter 3 Description Hardware, Chapter 7 Software, Chapter 9 Technical Data, Chapter 10 Standards and Approvals: Introductory sentence inserted Chapter 5.1 Unusual situations: 5.1.2 Sluggish touch behavior added Chapter 2.6 Add-On: Moved, new chapter number 3.2

# Instruction Manual: Touch Industrial PC

	<p>Chapter 4.1 Temperature test: Moved, new chapter number 9.6</p> <p>Chapter 4.2 IP Protection Class: Moved, new chapter number 9.7</p> <p>Chapter 9.5 Environmental Conditions: Ambient Temperature instead of Operating Temperature</p> <p>Chapter 9.6 Temperature test: Ambient Temperature instead of Operating Temperature</p>
04/2023 Rev. 04	<p>Chapter 1 Identification: Revision of Design of safety instructions</p> <p>Chapter 3.1 External Interfaces: Revision of the safety instruction External cable for Power Supply</p> <p>Chapter 4 Assembly and Commissioning: Renamin to Mounting</p> <p>Chapter 4 Mounting: Remove safety instruction Danger from electric shock. Insert safety instruction Power Supply.</p> <p>Chapter 4.2 Connection of the power supply: Insert safety instruction Connection power supply</p> <p>Chapter 9.3 Power Consumption: Insert Measures to avoid hazards</p> <p>Chapter 9.8 Display Specification: Wording adjusted</p>
06/2023 Rev. 05	<p>Chapter 1 Identification: Inserting the revision in the history</p> <p>Chapter 3.1 External Interfaces: Insert safety instruction Specification</p> <p>Chapter 4.7 Adjusting the faceplate: Description of the extension of the control elements</p> <p>Chapter 5.1 Function of the power button: Description of the function of the poer button.</p>

Table 1: History

# Instruction Manual: Touch Industrial PC

## Design of safety instructions

The general structure of the safety instructions is shown below:

<b>NOTICE</b>	
	<p><b>Type of hazard and source of hazard</b></p> <p>Consequences in the event of non-compliance with the guideline</p> <ul style="list-style-type: none"> <li>➤ Measures to avoid hazards</li> </ul>

The meaning of the colours of the safety instructions is shown below:

<b>⚠ DANGER</b>	
	<p><b>Indicates an imminent danger</b></p> <p>Failure to follow the instructions may result in death or serious injury.</p>

<b>⚠ WARNING</b>	
	<p><b>Indicates a dangerous situation</b></p> <p>Failure to follow the instructions may result in serious injury.</p>

<b>⚠ CAUTION</b>	
	<p><b>Indicates a possible dangerous situation</b></p> <p>Failure to follow the instruction may result in injury.</p>

<b>NOTICE</b>	
	<p><b>Indicates user tips and useful information</b></p> <p>Important information to avoid malfunctions.</p>

# Instruction Manual: Touch Industrial PC

## 2 Product description

Every industry has its own requirements for machine and system operation. To meet all of them, there are different housing variants with industry-specific features.

All touch panels are equipped with multitouch technology in various inch sizes as standard. This means that gesture control, as used on tablets or smart phones, is no problem. This makes machine operation particularly user-friendly.

Christ also offers the greatest possible flexibility in terms of operating systems with Windows 10 or Linux distributions. The sophisticated device design enables use in large temperature ranges completely without fans. This enables versatile use without any maintenance effort.

Industrial PCs with their robust housing design are ideal for use in demanding industrial environments. Due to optimal touch configuration, smooth operation is possible even with gloves. Even with residues on the display such as moisture, dirt or oils, the touch panel can be operated without errors. The anodized front frame protects the panel from mechanical influences.

The extension of the protection class is particularly easy by using a rear cover extension. In this way, protection class IP65 is achieved. The Industrial PCs can be mounted on support arms as well as installed in housing cutouts.

The hygienic version of the touch panel has a stainless steel housing and is completely IP69 protected. It is particularly suitable for use in hygienically demanding environments such as the pharmaceutical or food industry. Glove operation is also possible here with the help of an adapted touch.

Another aspect is the scalability of performance. A distinction is made here between different configuration levels: monitor, distance monitor (for use over long distances), web panel and particularly powerful panel PCs with Intel® Celeron® or Core™ i3, i5, or i7 processors.

# Instruction Manual: Touch Industrial PC

## 2.1 System Overview

### Argon

CPU	Intel® Celeron™ N3350 1.1 GHz
Graphic	Intel® HD Graphics 500 200 Hz
Memory	1 x DDR3 Slot, max. 8 GB
BIOS	AMI Optio 5 BIOS
Interfaces	2 x USB 3.0 Port (Type A) 2 x 1 GBit Ethernet (RJ45) 1 x RS-232 / RS-422 / RS-485 (Bios setting) (RJ50) 1 x Display Port 1.0

Table 2: System overview Argon

### Titanium

CPU	Intel® Celeron™ 3965U 2.2 GHz	Intel® Core™ i3-7100U 2.4 GHz	Intel® Core™ i5-7300U 2.6 GHz	Intel® Core™ i7-7600U 2.8 GHz
Graphic	Intel® HD Graphics 610	Intel® HD Graphics 620		
Memory	2 x DDR4 slot, in summary max. 32 GB			
BIOS	AMI Optio 5 BIOS			
Interfaces	4 x USB: 2 x USB 2.0 Port (Type A); 2 x USB 3.0 Port (Type A) 2 x 1 GBit Ethernet (RJ45) 1 x RS-232 / RS-422 / RS-485 (Bios setting) (Sub-D) 1 x Display Port 1.1			

Table 3: System overview Titanium



# Instruction Manual: Touch Industrial PC

## 2.2 Housing Variant VESA

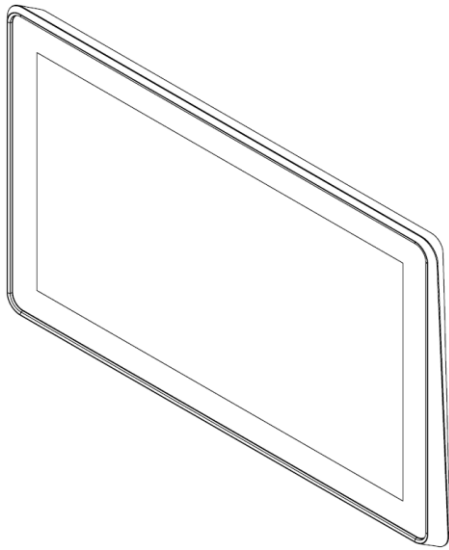

Illustration 1: VESA Front

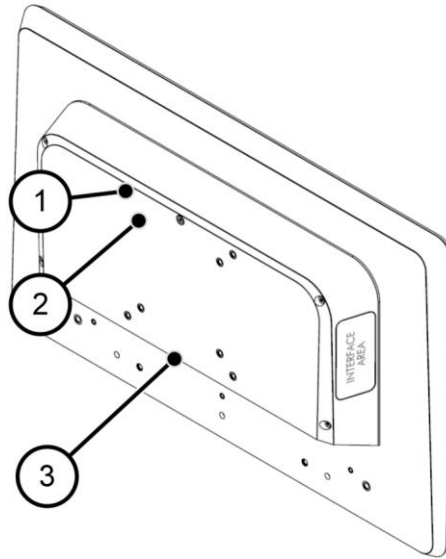

Illustration 2: VESA Rear

1	VESA MIS-D, 100
2	VESA MIS-D, 75
3	Interface Area

Table 4: VESA Front and VESA Rear

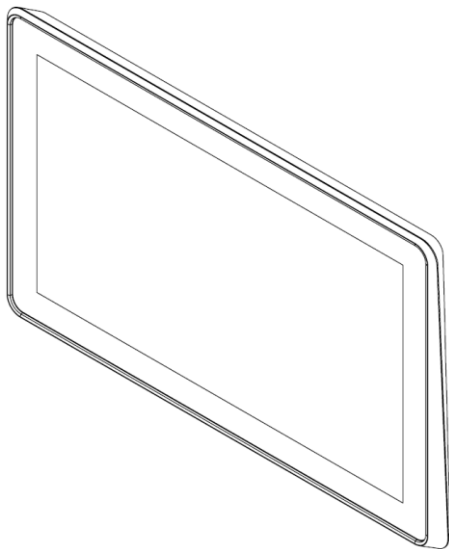

Illustration 3: VESA IP65 Front

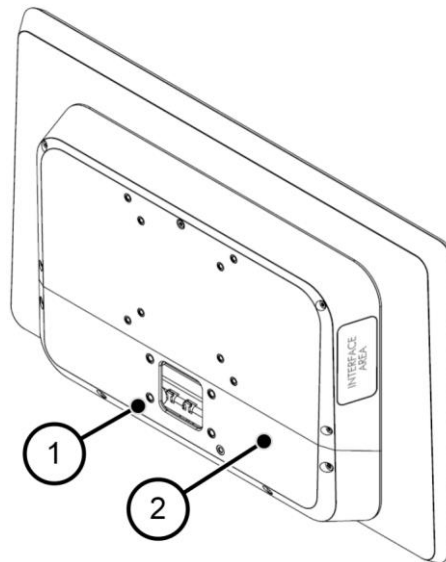

Illustration 4: VESA IP65 Rear

1	VESA MIS-D, 75
2	Interface Cover

Table 5: VESA IP65 Front and VESA IP65 Rear

# Instruction Manual: Touch Industrial PC

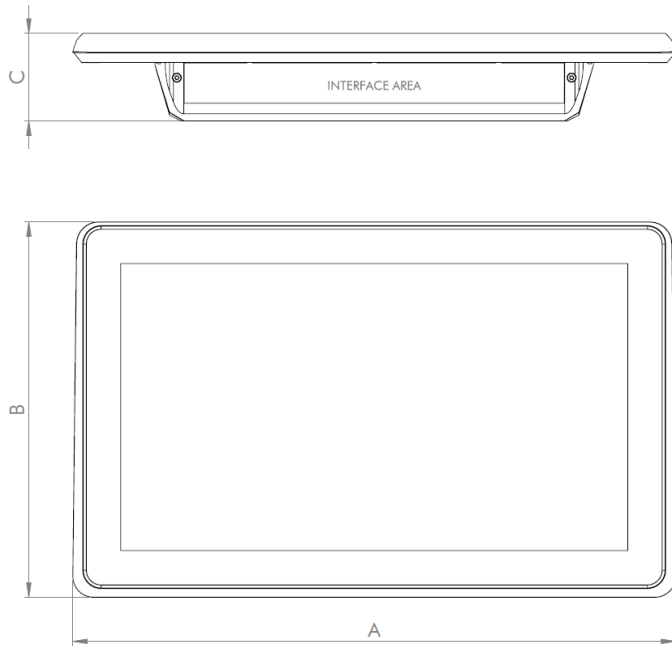

Illustration 5: Dimensions VESA

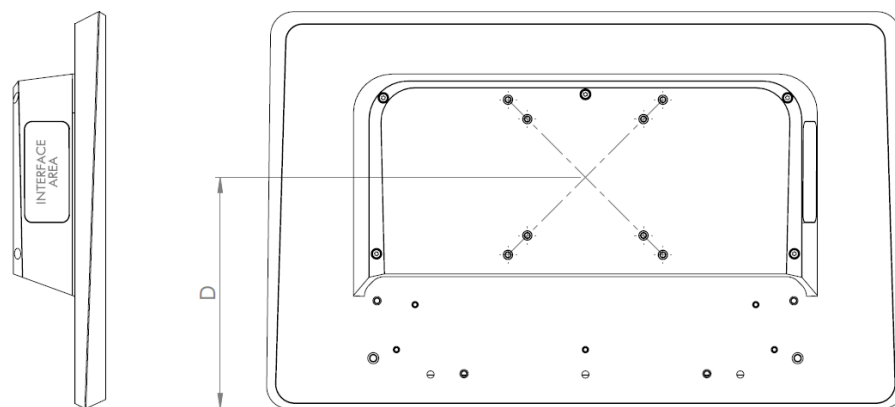

Illustration 6: Dimensions VESA Rear

Dimensions are given in millimeters.

# Instruction Manual: Touch Industrial PC

Size	A	B	C	D
7"	211	144	55	75
10.1"	276	190	58	105
10.4"	274	215	58	130
12.1"	325	222	58	137
13.3"	357	224	58	148
15"	369	288	58	149
15.6"	412	256	58	149
18.5"	477	293	61	149
21.5"	548	334	61	149
24"	604	367	61	149

Table 6: Dimensions VESA

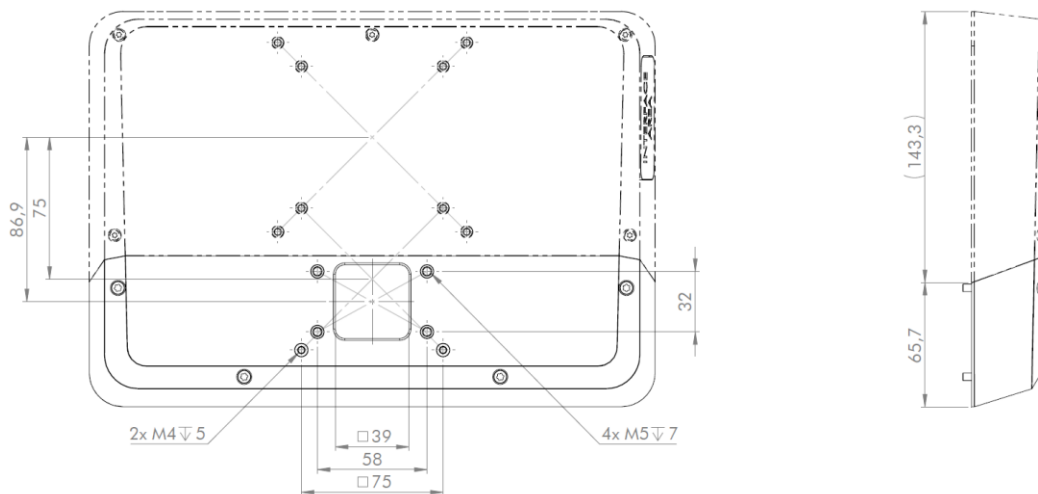

Illustration 7: VESA IP65 Cover

The cover for IP65 protection is available for sizes 13.3 to 24.

# Instruction Manual: Touch Industrial PC

## 2.3 Housing Variant VESA Automation

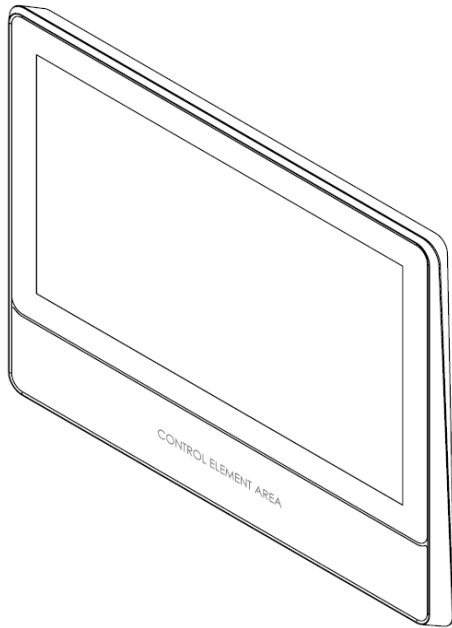

Illustration 8: VESA Automation Front

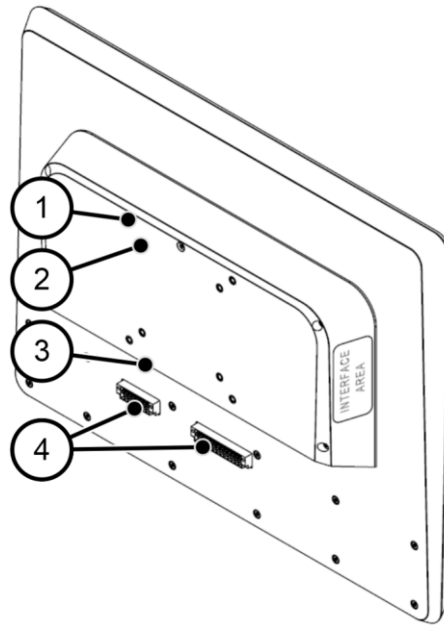

Illustration 9: VESA Automation Rear

1	VESA MIS-D, 100
2	VESA MIS-D, 75
3	Interface Area
4	Extension Connector

Table 7: VESA Automation Front and VESA Automation Rear

# Instruction Manual: Touch Industrial PC

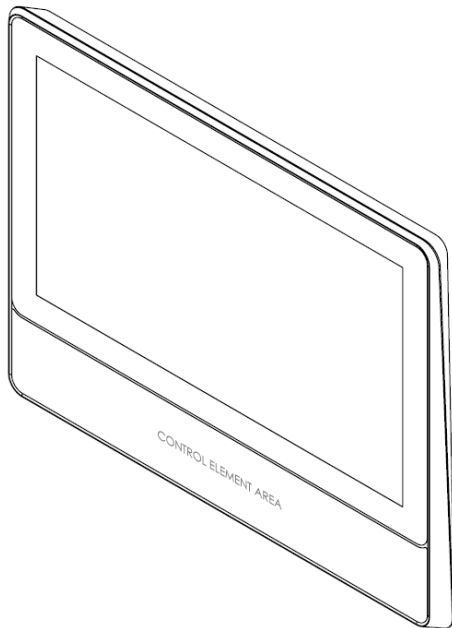

Illustration 10: VESA Automation IP65 Front

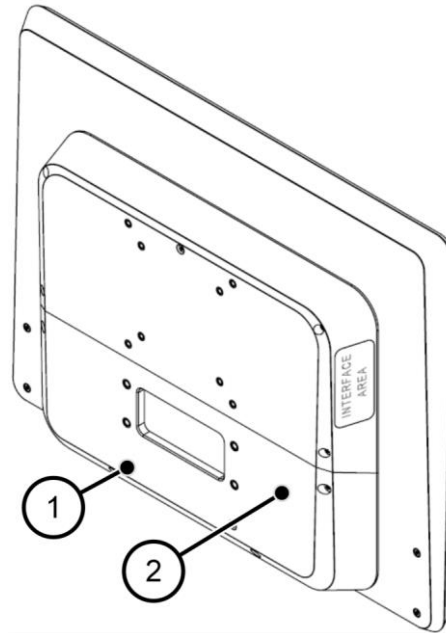

Illustration 11: VESA Automation IP65 Rear

1	VESA MIS-D, 100
2	Interface Cover

Table 8: VESA Automation IP65 Front and VESA Automation IP65 Rear

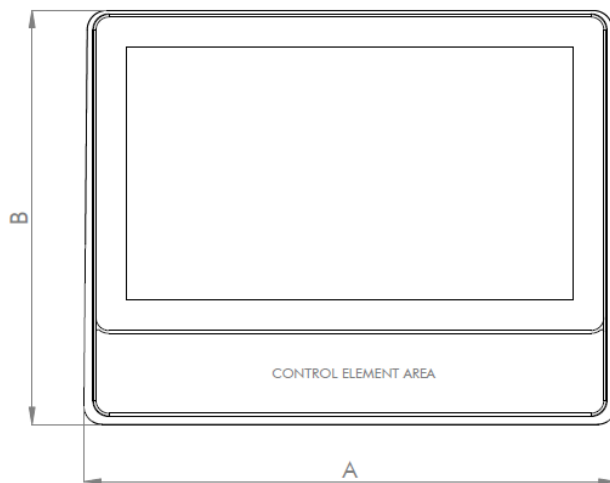
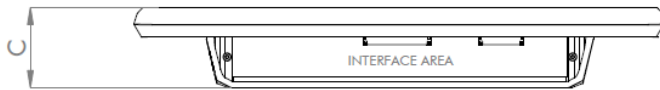

Illustration 12: Dimensions VESA Automation

# Instruction Manual: Touch Industrial PC

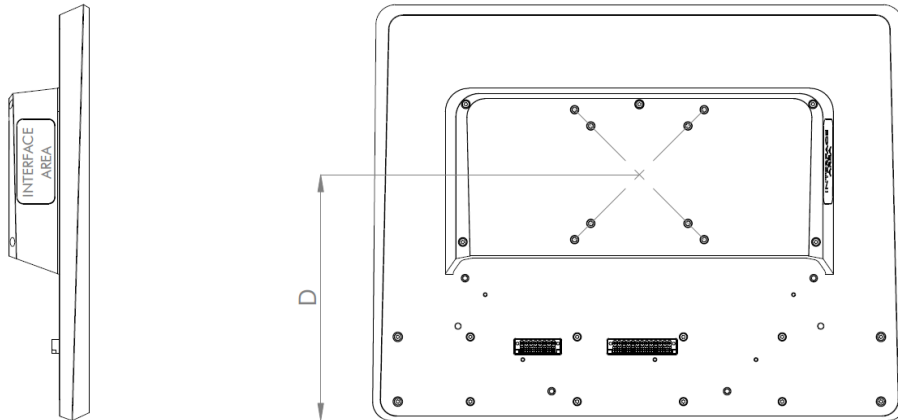

Illustration 13: Dimensions VESA Automation Rear

Dimensions are given in millimeters.

Size	A	B	C	D
13.3"	357	288	62	189
15.6"	412	320	62	189
18.5"	477	357	62	189
21.5"	548	398	62	189
24"	604	431	62	189

Table 9: Dimensions VESA Automation

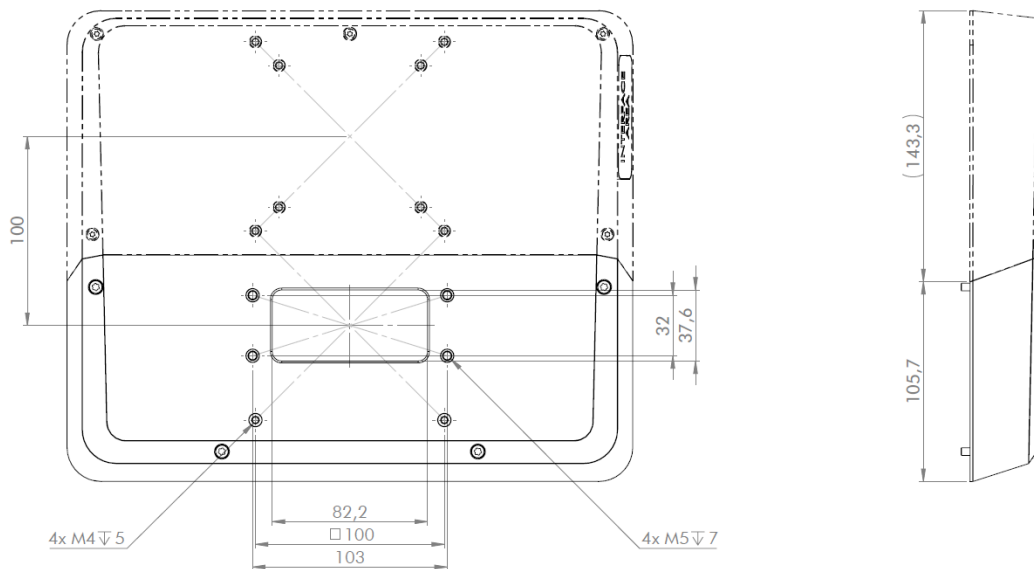

Illustration 14: VESA Automation IP65 Cover

The cover for IP65 protection is available for sizes 13.3 to 24.

# Instruction Manual: Touch Industrial PC

## Pushbuttons



Series	SHORTRON® base-plate mounting
Degree of protection	IP65
Travel	2.3 mm
Illumination	Yes, white LED
Labeling Option	Yes <sup>1</sup>
Front Bezel	Silver-Coloured
Operating Temperature	-25 °C ... 70 °C
Contact Elements	max. 2 x NC / 2 x NO / 1 x NC + 1 x NO
Nameplate	Transparent: Blue, Yellow, Green, Transparent, Red, White Non-transparent: Black

## Key Lock Switch



Series	SHORTRON® base-plate mounting
Degree of protection	IP65
Switchin function	Latching
Illumination	No
Labeling Option	No
Front Bezel	Silver-Coloured
Operating Temperature	-25 °C ... 70 °C
Contact Elements	max. 2 x NC / 2 x NO / 1 x NC + 1 x NO

<sup>1</sup> Possible designation plates are provided by your contact person

# Instruction Manual: Touch Industrial PC

## Selector Switch



Series	SHORTRON® base-plate mounting
Degree of protection	IP65
Switching function	Latching / non latching
Illumination	Yes, white LED
Labeling Option	No
Front Bezel	Silver-Coloured
Operating temperature	-25 °C ... 70 °C
Contact Elements	max. 2 x NC / 2 x NO / 1 x NC + 1 x NO

## Emergency Stop



Series	SHORTRON® base-plate mounting
Type	FRVKZ
Degree of protection	IP65
Travel	2.3 mm
Illumination	No
Labelling Option	No
Front Bezel	Yellow
Operating Temperature	-25°C ... 70°C
Contact Elements	2 x Ö + 1 x S
Switching Position Indicator	Yes
Release	Twist right or left
Anti-lock Collar	Yes

## USB



Degree of protection	IP65
USB	USB 2.0
Illumination	No
Labelling Option	No
Front Bezel	Black
Operating Temperature	-25°C ... 80°C



# Instruction Manual: Touch Industrial PC

## RFID

Manufacturer	ELATEC GmbH
Type	TWN4 MULTITECH NANO M
Degree of protection	IP65
Frequencies	125 kHz / 13.56 MHz
Operating temperature	-25°C ... 80°C
Transponder	<p><b>125 KHz:</b> AWID, Cardax<sup>1</sup>, CASI-RUSCO, Deister<sup>1</sup>, EM4100, 4102, 4200<sup>2</sup>, EM4050, 4150, 4450, 4550, EM4305<sup>3</sup>, FDX-B<sup>4</sup>, EM4105<sup>4</sup>, UltraProx<sup>4</sup>, HITAG 1<sup>5</sup>, HITAG 2<sup>5</sup>, HITAG S<sup>5</sup>, ICT<sup>6</sup>, IDTECK, Isonas, Keri, Miro, Nedap<sup>1</sup>, PAC<sup>6</sup>, Pyramid, Q5, T5557, T5567, T5577, TIRIS/HDX<sup>4</sup>, TITAN (EM4050), UNIQUE, ZODIAC</p> <p><b>13.56 MHz / ISO14443A:</b> LEGIC Advant<sup>7</sup>, MIFARE Classic EV1<sup>8</sup>, MIFARE Classic, MIFARE Mini, MIFARE DESFire EV1, MIFARE DESFire EV2<sup>9</sup>, MIFARE DESFire Light<sup>6</sup>, MIFARE Plus S, X, MIFARE Pro X<sup>10</sup>, MIFARE Smart MX<sup>10</sup>, MIFARE Ultralight, MIFARE Ultralight C, MIFARE Ultralight EV1<sup>8</sup>, NTAG2xx, SLE44R35<sup>10</sup>, SLE66Rxx (my-d move)<sup>10</sup>, Topaz</p> <p><b>13.56 MHz / ISO18092 ECMA-340:</b> NFC Forum Tag 1-5, NFC Peer-to-Peer, Sony FeliCa<sup>11</sup>, NFC Active and passive communication mode</p> <p><b>13.56 MHz / ISO14443B:</b> Calypso<sup>10</sup>, Calypso Innovatron protocol<sup>10</sup>, CEPAS<sup>10</sup>, HID iCLASS<sup>7</sup>, Moneo<sup>10</sup>, Pico Pass<sup>12</sup>, SRI4K, SRIX4K, SRI512, SRT512</p> <p><b>13.56 MHz / ISO15693:</b> EM4x33<sup>10</sup>, EM4x35<sup>10</sup>, HID iCLASS<sup>7</sup>, HID iCLASS SE/SR<sup>7</sup>, ICODE SLI, LEGIC Advant<sup>7</sup>, M24LR16/64, MB89R118/119, SRF55Vxx (my-d vicinity)<sup>10</sup>, Tag-it, PicoPass<sup>12</sup></p>

<sup>1</sup> hash value only

<sup>2</sup> only emulation of 4100, 4102

<sup>3</sup> from FW V4.05

<sup>4</sup> 134.2 kHz only

<sup>5</sup> without encryption

<sup>6</sup> on request

<sup>7</sup> UID only

<sup>8</sup> read/write enhanced security features on request

<sup>9</sup> EV2/EV3 supported as part of the EV1 downward compatibility

<sup>10</sup> read/write in direct chip command mode

<sup>11</sup> UID + read/write public area

<sup>12</sup> UID only, read/write on request

## Instruction Manual: Touch Industrial PC

Manufacturer	ELATEC GmbH
Type	TWN4 MULTITECH NANO LEGIC 42 M
Degree of protection	IP65
Frequencies	125 kHz / 13.56 MHz
Operating temperature	-25°C ... 80°C
Transponder	<p><b>125 KHz:</b> AWID, Cardax<sup>1</sup>, CASI-RUSCO, Deister<sup>1</sup>, EM4100, EM4102, EM4200<sup>2</sup>, EM4050, EM4150, EM4450, EM4550, EM4305, HITAG 1<sup>3</sup>, HITAG 2<sup>3</sup>, HITAG S<sup>3</sup>, ICT<sup>4</sup>, IDTECK, ISONAS, Keri, Miro, Nedap<sup>1</sup>, Pyramid, Q5, T5557, T5567, T5577, TITAN (EM4050), UNIQUE, ZODIAC</p> <p><b>13.56 MHz / ISO14443A:</b> LEGIC Advant, MIFARE Classic EV1<sup>5</sup>, MIFARE Classic, MIFARE Mini, MIFARE DESFire EV1, MIFARE DESFire EV2<sup>6</sup>, MIFARE DESFire EV3<sup>6</sup>, MIFARE DESFire Light<sup>4</sup>, MIFARE Plus S/X, MIFARE Smart MX<sup>7</sup>, MIFARE Ultralight, MIFARE Ultralight C, MIFARE Ultralight EV1<sup>5</sup>, NTAG2xx, SLE44R35<sup>7</sup>, SLE66Rxx (my-d move)<sup>7</sup>, HID iCLASS DESFire<sup>8</sup>, HID iCLASS MIFARE Classic<sup>8</sup>, HID iCLASS SEOS<sup>8</sup></p> <p><b>13.56 MHz / ISO18092 ECMA-340:</b> NFC Forum Tag 1-5<sup>9</sup>, Sony FeliCa<sup>10</sup></p> <p><b>13.56 MHz / ISO14443B:</b> Calypso<sup>7</sup>, CEPAS<sup>7</sup>, HID iCLASS<sup>8</sup>, Pico Pass<sup>8</sup></p> <p><b>13.56 MHz / ISO15693:</b> EM4x33<sup>7</sup>, EM4x35<sup>7</sup>, HID iCLASS<sup>8</sup>, HID iCLASS SE/SR/Elite<sup>8</sup>, ICODE SLI, LEGIC Advant, M24LR16/64, SRF55Vxx (my-d vicinity)<sup>7</sup>, Tag-it, PicoPass<sup>8</sup></p> <p><b>LEGIC Prime:</b> LEGIC Prime</p>

### Profinet

The GSD file for project planning is provided by Christ. This describes the input/output image of the Christ device and must be embedded in the configuration software. The input/output image or the variables can then be used in the control programme.

The IP address is assigned to the IO device (Profinet module installed in the Christ device) by the PROFINET IO controller (PLC controller of the customer).

<sup>1</sup> hash value only

<sup>2</sup> only emulation of 4100, 4102

<sup>3</sup> without encryption

<sup>4</sup> on request

<sup>5</sup> read/write enhanced security features on request

<sup>6</sup> supported as part of the EV1 downward compatibility

<sup>7</sup> read/write in direct chip command mode

<sup>8</sup> UID only

<sup>9</sup> NFC Forum Tag 1 not supported

<sup>10</sup> UID + read/write public area

# Instruction Manual: Touch Industrial PC

In the delivery state, the station name of the IO device is not set. This must be assigned by the IO controller according to the Profinet specification so that communication can take place.

For more information on Profinet, visit the homepage <https://www.profinet.com/>.

## **EtherCAT**

The XML file for project planning is provided by Christ. This describes the input/output image of the Christ device and must be embedded in the configuration software. The input/output image or the variables can then be used in the control programme.

For more information on EtherCAT, visit the homepage <https://www.ethercat.org/>.

## **EtherNet/IP**

By default, the Ethernet/IP address is assigned via DHCP. A DHCP server must be available in the network for this.

To be able to assign the IP address manually, there is, for example, the tool BootP that simulates a DHCP server.

Alternatively, there is the option of having Christ assign a fixed IP address.

The EDS file for project planning is provided by Christ. This describes the input/output image of the Christ device and must be embedded in the configuration software. The input/output image or the variables can then be used in the control programme.

For more information on EtherNet/IP, visit the homepage <https://www.odva.org/>.

# Instruction Manual: Touch Industrial PC

## 2.4 Housing variant Front Panel

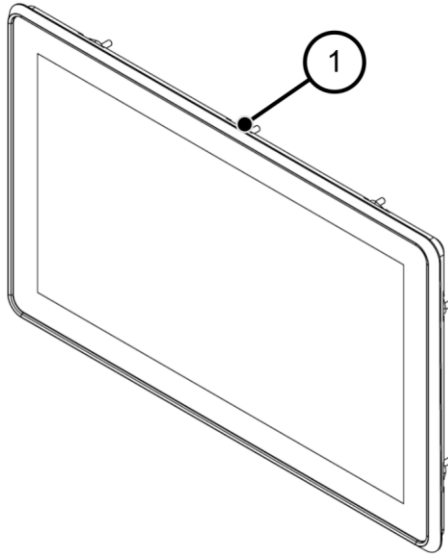

Illustration 15: Front Panel Front

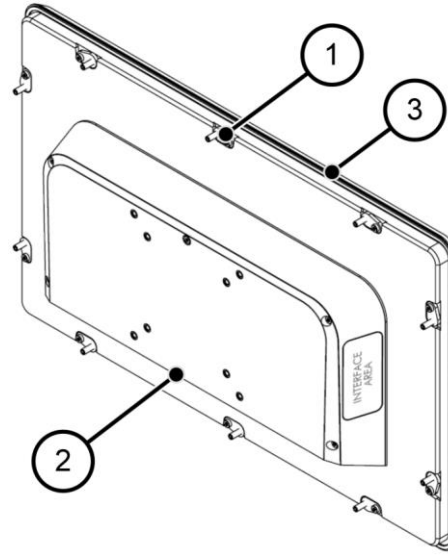

Illustration 16: Front Panel Rear

1	Fastening Clamp
2	Interface Area
3	Seal

Table 10: Front Panel Front und Front Panel Rear

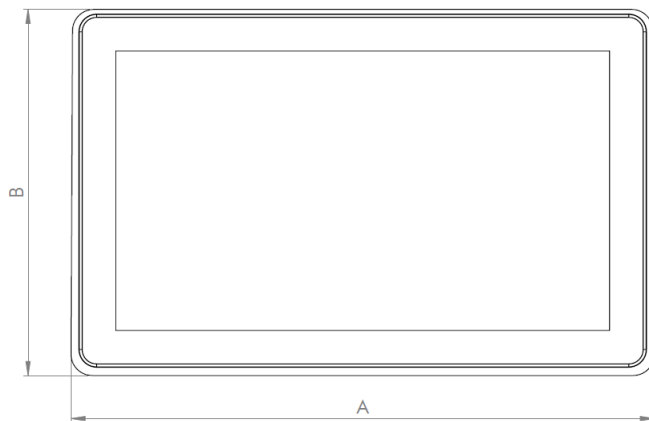
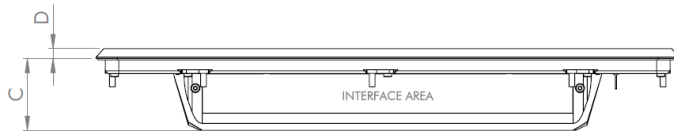

Illustration 17: Dimensions Front Panel

# Instruction Manual: Touch Industrial PC

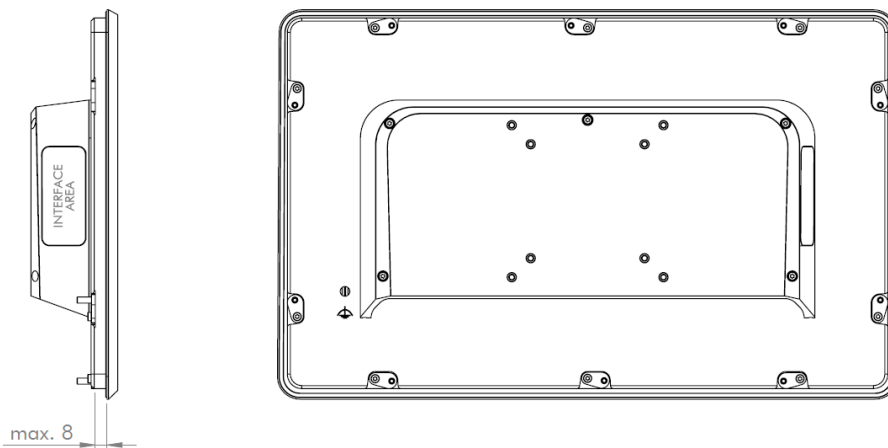

Illustration 18: Dimensions Front Panel Rear

The drawing of the Front Panel is exemplary and may show deviations to the device. The detailed technical drawing can be found in the specific data sheet.

Dimensions are given in millimeters.

Size	A	B	C	D
7"	208	145	47	7
10.1"	273	190	50	7
10.4"	274	217	50	7
12.1"	322	222	52	7
13.3"	354	224	50	7
15"	366	288	52	7
15.6"	409	256	52	7
18.5"	474	293	52	7
21.5"	545	334	52	7
24"	601	367	54	7

Table 11: Dimensions Front Panel

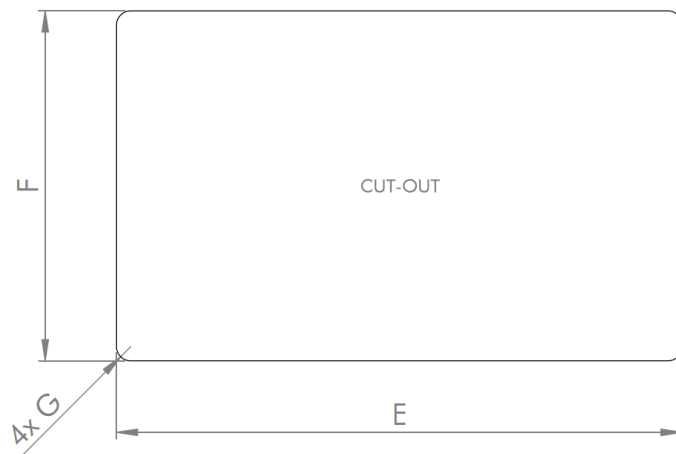

Illustration 19: Dimensions Front Panel Cutout

# Instruction Manual: Touch Industrial PC

Dimensions are given in millimeters.

Size	E	F	G
7"	196	134	R 10
10.1"	262	179	R 10
10.4"	262	206	R 10
12.1"	310	211	R 10
13.3"	343	213	R 10
15"	355	277	R 10
15.6"	397	245	R 10
18.5"	463	283	R 10
21.5"	533	323	R 10
24"	590	356	R 10

Table 12: Dimensions Front Panel Cutout

## 2.5 Housing Variant Open Frame

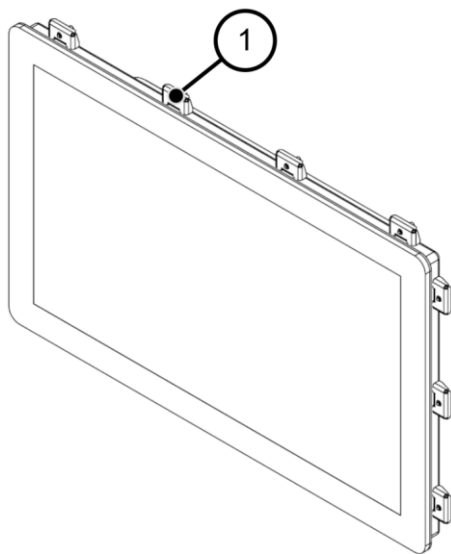

Illustration 20: Open Frame Front

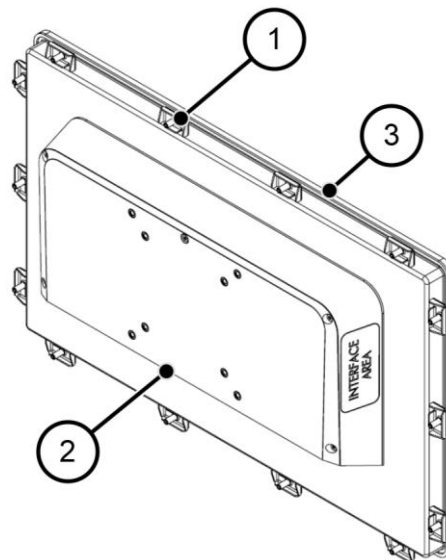
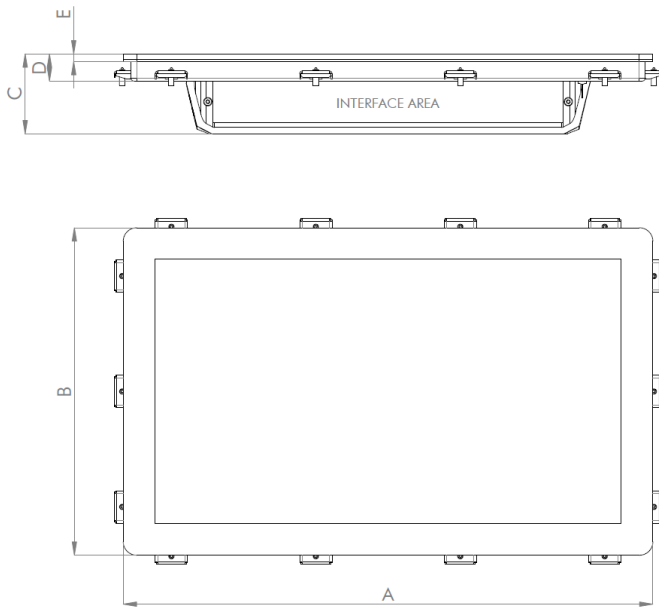

Illustration 21: Open Frame Rear

1	Fastening Clamp
2	Interface Area
3	Seal

Table 13: Open Frame Front und Open Frame Rear

# Instruction Manual: Touch Industrial PC



*Illustration 22: Dimensions Open Frame*

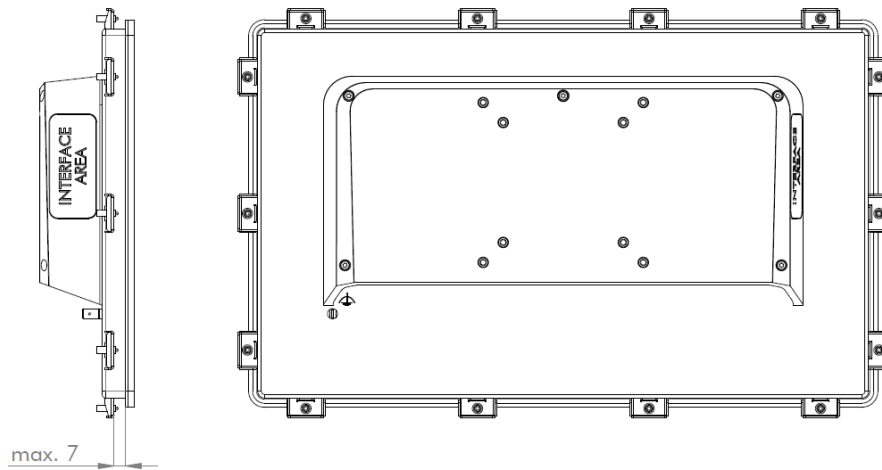

*Illustration 23: Dimensions Open Frame Rear*

The drawing of the Open Frame is exemplary and may show deviations to the device. The detailed technical drawing can be found in the specific data sheet.

Dimensions are given in millimeters.

# Instruction Manual: Touch Industrial PC

Size	A	B	C	D	E
7"	192.2 ± 0.2	131.2 ± 0.2	56	20	5.7
10.1"	257.6 ± 0.2	176.2 ± 0.2	59	20	5.7
10.4"	254.8 ± 0.2	202 ± 0.2	59	20	5.7
12.1"	305.9 ± 0.2	208 ± 0.2	59	20	5.7
13.3"	338.7 ± 0.2	210.3 ± 0.2	59	20	5.7
15"	350.3 ± 0.2	274.3 ± 0.2	59	20	5.7
15.6"	393 ± 0.3	242.4 ± 0.3	59	20	5.7
18.5"	458.6 ± 0.3	279.6 ± 0.3	59	20	5.7
21.5"	528.8 ± 0.3	320.3 ± 0.3	59	20	5.7
24"	585.5 ± 0.3	353 ± 0.3	63	24	5.7

Table 14: Dimensions Open Frame



Illustration 24: Dimensions Open Frame Cutout Counterplate

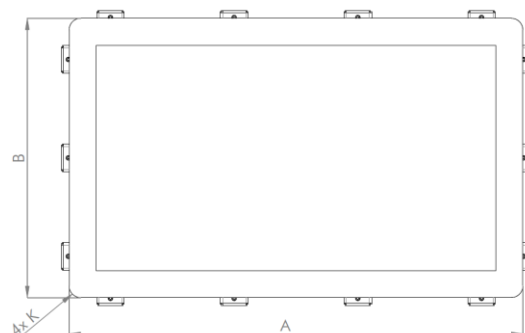

Illustration 25: Dimensions Open Frame Cutout Front- and Spacerplate

Dimensions are given in millimeters.

Size	F	G	H	K
7"	182	121	R 5	R10 ± 0.2
10.1"	248	166	R 5	R10 ± 0.2
10.4"	245	192	R 5	R10 ± 0.2
12.1"	296	198	R 5	R10 ± 0.2
13.3"	329	200	R 5	R10 ± 0.2
15"	340	264	R 5	R10 ± 0.2
15.6"	383	232	R 5	R10 ± 0.2
18.5"	449	270	R 5	R10 ± 0.2
21.5"	519	310	R 5	R10 ± 0.2
24"	575	343	R 5	R10 ± 0.2

Table 15: Dimensions Open Frame Cutout



# Instruction Manual: Touch Industrial PC

## Installation Open Frame

The actual cut-out-dimensions of the front- and spacerplate need to be subjected to the prevalent assembly situation (production tolerances, ambient temperature, etc.) and therefore to be defined by the customer.

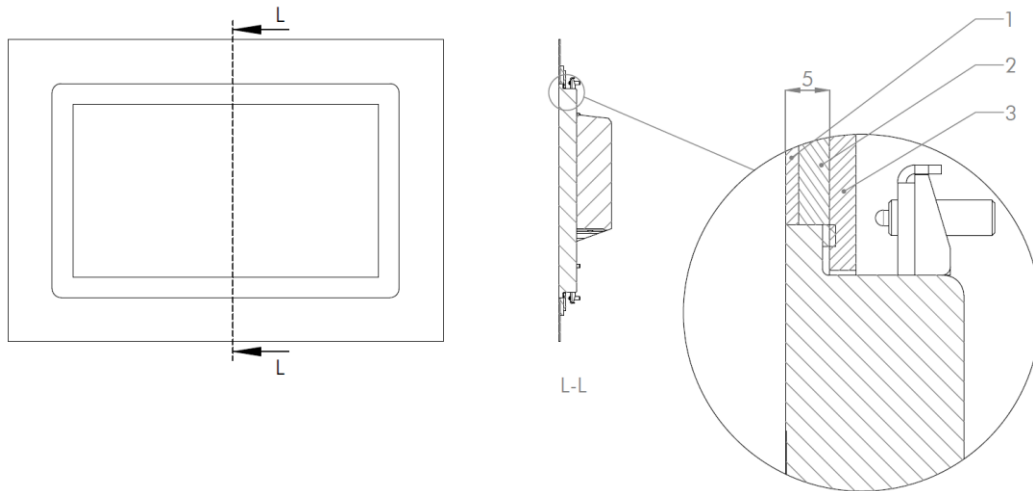

*Illustration 26: Installation Open Frame Cutout*



1	Frontplate
2	Spacerplate
3	Counterplate

# Instruction Manual: Touch Industrial PC

## 3 Description Hardware

The description of the hardware refers to the device interfaces and the possible extensions for the device.

### 3.1 External Interfaces

NOTICE	
	<p><b>External cable for Power Supply</b> Malfunction occur</p> <ul style="list-style-type: none"> <li>➤ Prepare a proper earth connection on the power supply</li> </ul>
NOTICE	
	<p><b>Signal and data cables</b> Malfunction occur</p> <ul style="list-style-type: none"> <li>➤ Signal and data cables must be shielded and of high quality.</li> </ul>
NOTICE	
	<p><b>Operating the interfaces outside their intended specification</b> Malfunctions occur and the electronics of the device can be damaged or completely broken</p> <ul style="list-style-type: none"> <li>➤ All interfaces must be operated within their specification. Only cables and components that meet the requirements for the intended use of the interfaces may be connected.</li> </ul>

#### Supply Connector screwable

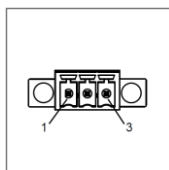

<b>Mating Connector</b>	Phoenix Connector MC 1,5 / 3-STF-3.5 (screwable)		
<b>PIN</b>	<b>Function</b>	<b>Description</b>	
1	GND	Ground	
2	FE	Functional Earth	
3	+24 VDC	Supply	

Table 16: Pinout Supply Connector screwable

#### USB Host 2.0 (Type A)

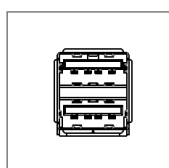

<b>PIN</b>	<b>Function</b>	<b>Description</b>
1	VBUS	USB VCC
2	D-	USB Data-
3	D+	USB Data+
4	GND	USB Ground

Table 17: Pinout USB 2.0

# Instruction Manual: Touch Industrial PC

## USB Host 3.0 (Type A)

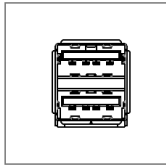

PIN	Function	Description
1	VBUS	USB VCC
2	D-	USB Data-
3	D+	USB Data+
4	GND	USB Ground
5	StdA_SSRX-	SuperSpeed transmitter differential pair
6	StdA_SSRX+	SuperSpeed transmitter differential pair
7	GND_DRAIN	Ground for signal return
8	StdA_SSTX-	SuperSpeed receiver differential pair
9	StdA_SSTX+	SuperSpeed receiver differential pair

Table 18: Pinout USB 3.0

## Ethernet 10BaseT 100BaseT

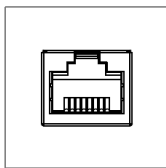

PIN	Function	Description
1	TX+	Transmit Data +
2	TX-	Transmit Data -
3	RX+	Receive Data+
4	--	--
5	--	--
6	RX-	Receive Data -
7	--	--
8	--	--

Table 19: Pinout Ethernet 10BaseT 100BaseT

## Ethernet Gigabit

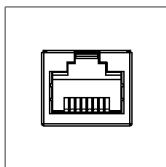

PIN	Function	Description
1	D1+	Transmit Data +
2	D1-	Transmit Data -
3	D2+	Receive Data+
4	D3+	Bidirectional +
5	D3-	Bidirectional -
6	D2-	Receive Data -
7	D4+	Bidirectional +
8	D4-	Bidirectional -

Table 20: Pinout Ethernet Gigabit

# Instruction Manual: Touch Industrial PC

## WLAN



<b>Mating Connector</b>	RP-SMA
<b>Transmission Standard</b>	802.11 ac/a/b/g/n (2.4 GHz, 5 GHz)

Table 21: Pinout WLAN

## Serial Connector (Titanium)

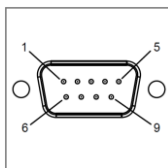

	RS-232		RS-422		RS-485	
PIN	Function	Description	Function	Description	Function	Description
1	DCD	Data Carrier Detect	TX-	Transmitter Differential Pair -	DATA-	Data Differential Pair A
2	RX	Receive Data	TX+	Transmitter Differential Pair +	DATA+	Data Differential Pair B
3	TX	Transmit Data	RX+	Receiver Differential Pair +	--	--
4	DTR	Data Transmit Ready	RX-	Receiver Differential Pair -	--	--
5	GND	Ground	GND	Ground	GND	Ground
6	DSR	Data Set Ready	--	--	--	--
7	RTS	Ready To Send	--	--	--	--
8	CTS	Clear To Send	--	--	--	--
9	RI	Ring Indicator	--	--	--	--

Table 22: Pinout Serial Connector Titanium

# Instruction Manual: Touch Industrial PC

## Serial Connector (Celeron N3350 Argon)

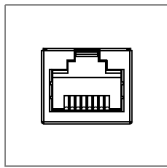

	RS-232		RS-422		RS-485	
PIN	Function	Description	Function	Description	Function	Description
1	DSR	Data Set Ready	--	--	--	--
2	GND	Ground	GND	Ground	GND	Ground
3	GND	Ground	GND	Ground	GND	Ground
4	TXD	Transmit Data	RX+	Receiver Differential Pair +	--	--
5	RXD	Receive Data	TX+	Transmitter Differential Pair +	DATA+	Data Differential Pair B
6	DCD	Data Carrier Detect	TX-	Transmitter Differential Pair -	DATA-	Data Differential Pair A
7	DTR	Data Terminal Ready	RX-	Receiver Differential Pair -	--	--
8	CTS	Clear To Send	--	--	--	--
9	RTS	Request To Send	--	--	--	--
10	RI	Ring Indicator	--	--	--	--

Table 23: Pinout Serial Connector Celeron N3350 Argon

## UPS

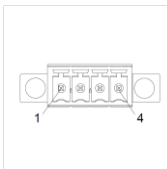

Mating Connector	MC 1,5/ 4-STF-3,5 (screwable)	
PIN	Function	Description
1	GND	Ground
2	GND	Ground
3	Capacitor	Capacitor
4	Capacitor State	Charge State Capacitor

Table 24: Pinout UPS

# Instruction Manual: Touch Industrial PC

## Display Port

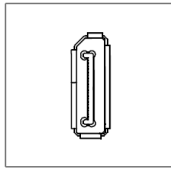

PIN	Function	Description
1	DP data 0+	DP data 0+
2	GND	Ground
3	DP data0-	DP data0-
4	DP data1 +	DP data1 +
5	GND	Ground
6	DP data1-	DP data1 -
7	DP data2+	DP data2+
8	GND	Ground
9	DP data2-	DP data2-
10	DP data3+	DP data3+
11	GND	Ground
12	DP data3-	DP data3-
13	CONFIG1 CAD	Cable adapter recognized
14	CONFIG2	Ground (Pull-Down)
15	AUX_CH+	Additional device +
16	GND	Ground
17	AUX_CH-	Additional device -
18	HPD	Hot Plug recognized
19	GND	Ground
20	DP_PWR 3,3V	Power Supply DP

Table 25: Pinout Display Port



With the DP1.0 it is not possible to display an image on DVI / HDMI devices. An active adapter with properties of DP++ is required for this.<sup>1</sup>



Display Port 1.1 is also known as "Dual-Mode Display Port" and "Display Port++". This allows compatibility with DVI and HDMI.

<sup>1</sup> The Argon board uses DP1.0

# Instruction Manual: Touch Industrial PC

## Phoenix DMCV 1,5/13-G1F-3,5-LR P20THR

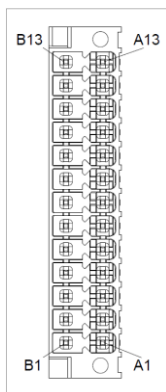

PIN	Function	Description	PIN	Function	Description
A1	P1_C1	Position 1 Contact 1	B7	P4_C2	Position 4 Contact 2
B1	P1_C2	Position 1 Contact 2	A8	P4_C24	Position 4 Contact 24
A2	P1_C24	Position 1 Contact 24 VDC	B8	P4_LED	Position 4 LED
B2	P1_LED	Position 1 LED	A9	E_C1	Emergency Stop Contact 1
A3	P2_C1	Position 2 Contact 1	B9	E_C2	Emergency Stop Contact 2
B3	P2_C2	Position 2 Contact 2	A10	E_C3	Emergency Stop Contact 3
A4	P2_C24	Position 2 Contact 24 VDC	B10	E_C4	Emergency Stop Contact 4
B4	P2_LED	Position 2 LED	A11	E_C5	Emergency Stop Contact 5
A5	P3_C1	Position 3 Contact 1	B11	E_C6	Emergency Stop Contact 6
B5	P3_C2	Position 3 LED Contact 2	A12	GND	Ground
A6	P3_C24	Position 3 Contact 24 VDC	B12	24 VDC	+24 VDC
B6	P3_LED	Position 3 LED	A13	GND	Ground
A7	P4_C1	Position 4 Contact 1	B13	24 VDC	+24 VDC

Table 26: Pinning Phoenix DMCV 1,5/13-G1F-3,5-LR P20THR

The pin assignment may vary. This can be found in the device-specific data sheet.

## Phoenix DMCV 1,5/8-G1F-3,5-LR P20THR

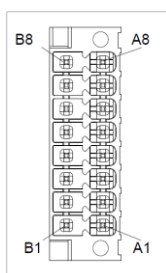

PIN	Function	Description	PIN	Function	Description
A1	P5_C1	Position 5 Contact 1	A5	P7_C1	Position 7 Contact 1
B1	P5_C2	Position 5 Contact 2	B5	P7_C2	Position 7 Contact 2
A2	P5_C24	Position 5 Contact 24 VDC	A6	P7_C24	Position 7 Contact 24 VDC
B2	P5_LED	Position 5 LED	B6	P7_LED	Position 7 LED
A3	P6_C1	Position 6 Contact 1	A7	P8_C1	Position 8 Contact 1

# Instruction Manual: Touch Industrial PC

<b>B3</b>	P6_C2	Position 6 Contact 2	<b>B7</b>	P8_C2	Position 8 Contact 2
<b>A4</b>	P6_C24	Position 6 Contact 24 VDC	<b>A8</b>	P8_C24	Position 8 Contact 24 VDC
<b>B4</b>	P6_LED	Position 6 LED	<b>B8</b>	P8_LED	Position 8 Contact LED

Table 27: Pinning Phoenix DMCV 1,5/8-G1F-3,5-LR P20THR

The pin assignment may vary. This can be found in the device-specific data sheet.

## 3.2 Add-On

In the following all extension possibilities are shown.

### 3.2.1 UPS (Uninterruptible Power Supply)

<b>Energy Storage</b>	400 Ws / 650 Ws
<b>Charge Duration</b>	90 % in 45 seconds 100 % in 80 seconds
<b>Configuration</b>	Shutdown Time Dimming Time Dimming Intensity

Energy storage value: see technical data sheet.

The instruction for the UPS can be found in the download section of the Christ website: [Downloads](#)

The device was operated with the following conditions: operating system Windows 10 IoT, no applications, display brightness 0 %.

It must be ensured that the customer application is ended quickly enough for the panel to shut down properly. Otherwise no protection against data loss or any other disfunction can be guaranteed. Depending on the CPU utilization, display and peripherals, the buffer time can be significantly shorter.

**The exact buffer duration must be determined anew in every system setup.**

<b>Intel® Celeron™ 3965U</b>	59 s
<b>Intel® Core™ i3-7100U</b>	57 s
<b>Intel® Core™ i5-7300U</b>	34 s
<b>Intel® Core™ i7-7600U</b>	38 s
<b>Intel® Celeron™ N3350</b>	99 s

Table 28: UPS buffer duration

### 3.2.2 Add On Interface Main Device



# Instruction Manual: Touch Industrial PC

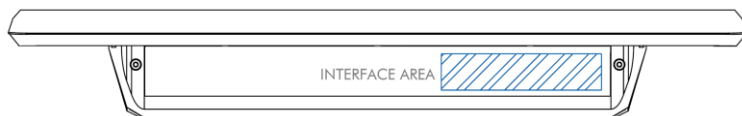

## Ethernet (1 x 100 Mbit + 2 x USB 2.0)

<b>Interface Ethernet</b>	1 x RJ45
<b>Data Rate</b>	100 Mbit
<b>Interface USB</b>	2 x USB Host 2.0 (Type A)
<b>Max. Workload</b>	0,5 A for both USB interfaces

Table 29: Add On Ethernet and USB

## WLAN Connector

<b>WLAN Standards</b>	802.11 ac/a/b/g/n (2.4 GHz, 5 GHz)
<b>Interface</b>	SMA

Table 30: Wireless LAN

## 3.2.3 Add On Interface Side

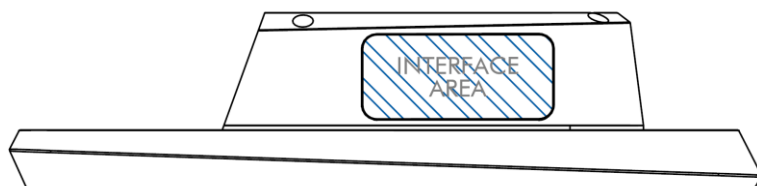

### USB 2.0 side

<b>Interface</b>	1 x USB Host 2.0 (Type A)
<b>Degree of protection</b>	IP64 (IP67 with protection cap)

Table 31: Add On side USB 2.0

### USB 3.0 side (only Titanium Board)

<b>Interface</b>	1 x USB Host 3.0 (Type A)
<b>Degree of protection</b>	IP64 (IP67 with protection cap)

Table 32: Add On side USB 3.0

The USB 3.0 interface side is only supported by devices with Titanium Board.

### Power Button side



<b>Type</b>	1 x MCS 16 (Manufacturer: Schurter)
<b>Degree of protection</b>	IP65

Table 33: Add On side Power Button

# Instruction Manual: Touch Industrial PC

## 4 Mounting

This chapter describes all the steps for assembly. The following warnings are safety instructions that must be applied throughout the assembly chapter and in every other life cycle of the device.

<b>NOTICE</b>	
	<p><b>Power Supply</b></p> <p>Disturbance of the proper operation</p> <ul style="list-style-type: none"> <li>➤ The device must be operated with protective low voltage (&lt; 28.8 VDC).</li> </ul>
<b>⚠ WARNING</b>	
	<p><b>Dropping a device</b></p> <p>Injuries and bruises to the legs and / or feet</p> <ul style="list-style-type: none"> <li>➤ Wear safety shoes</li> </ul>

### Note for the installation site

This device is not designed for outdoor use.

Make sure that the ambient temperature and humidity are within the ranges which are specified under [Environmental Conditions](#).

Do not install the device directly in the sunlight.

Make sure that the device is installed so that is accessible for the operator.

### Installation instructions

Check the package contents for any visible damage and for completeness.

In case of damage, do not install the device and contact the [Christ Service](#).

### Preparing the Cut-Out

The strength of the material of the mounting cutout must be sufficiently high.

The dimensions for the mounting cutouts are listed in the chapters [Housing variant front panel](#) and [Open Frame](#) .

## 4.1 Torque

All screws must be tightened with a minimum torque.

Screw	Torque
M3	1 Nm
M4	2,3 Nm

# Instruction Manual: Touch Industrial PC

## 4.2 Connection of the power supply

<b>NOTICE</b>	
	<p><b>Short circuit</b> Power Supply / device may be damaged</p> <p>➤ The power supply connection must be mounted in a voltage-free state.</p>

Use conductors with a cross-section of 0.75 mm<sup>2</sup> to 1.5 mm<sup>2</sup>. Use the MC 1,5/ 3-STF-3,5 BKBDWH:GND Q PCB connector from Phoenix.

Strip the insulation from the individual wires of the conductor (1). Insert these into the connection contacts (3) of the PCB connector and tighten the screw contacts (2) with a screwdriver and a maximum torque of 0.3 Nm.

The rear view (4) of the connector is shown for clarification.

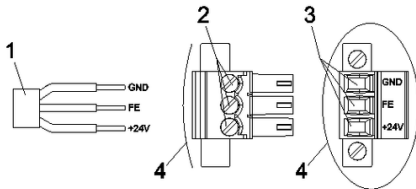

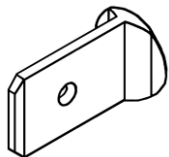

Illustration 27: Connection of the power supply

## 4.3 Earth Connection

<b>NOTICE</b>	
	<p><b>Earthing not connected</b> Not guaranteed functionality of the device</p> <p>➤ All earth connections must be connected to an earth point</p>

At the earthing connection, a line must be laid to the central earthing point of the control cabinet or the system. The earthing connection is marked with a label.



Earth connection



Label

# Instruction Manual: Touch Industrial PC

## 4.4 Mounting VESA and VESA Automation

### VESA

The VESA housing variant is executed in two different VESA sizes.

- VESA MIS-D, 75
- VESA MIS-D, 100

There are four mounting threads with the measurement of M4 x 5. The fixing screws are not included in the delivery attachment of the device because of the different installation situation. In the assembly drawing, any support arm was used as an example.

#### Step 1:

Dock the unit onto the support arm and screw it on

#### Final situation:

Device is mounted to the support arm

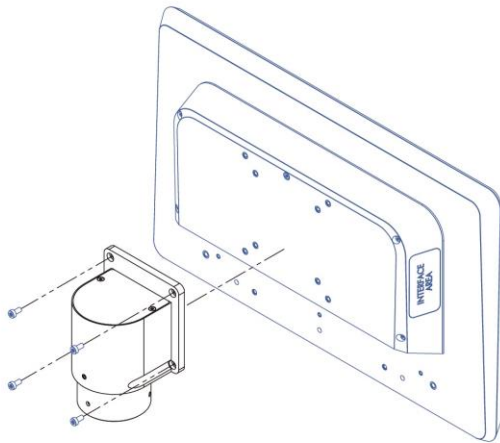

*Illustration 28: Mounting VESA Step 1*

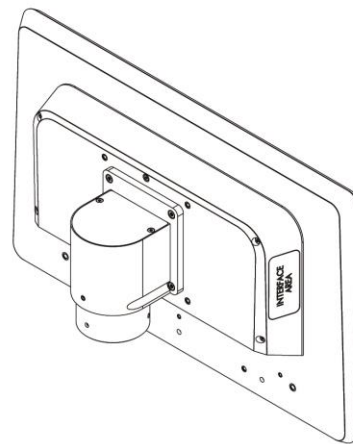

*Illustration 29: Mounting VESA final situation*

# Instruction Manual: Touch Industrial PC

## VESA IP65

For the housing variant VESA which has included the IP65 cover, the device can only be mounted with the VESA MIS-D, 75 if the cables are routed through the cutout.

There are four mounting threads with the measurement of M4 x 5. The fixing screws are not included in the delivery attachment of the device because of the different installation situation.

### Initial situation

Mounting arm and device are not connected

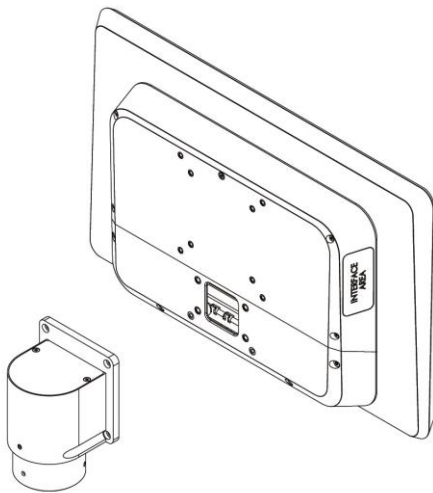

Illustration 30: Mounting VESA IP65 initial situation

### Step 1:

Loosen the screws of the IP cover and remove it

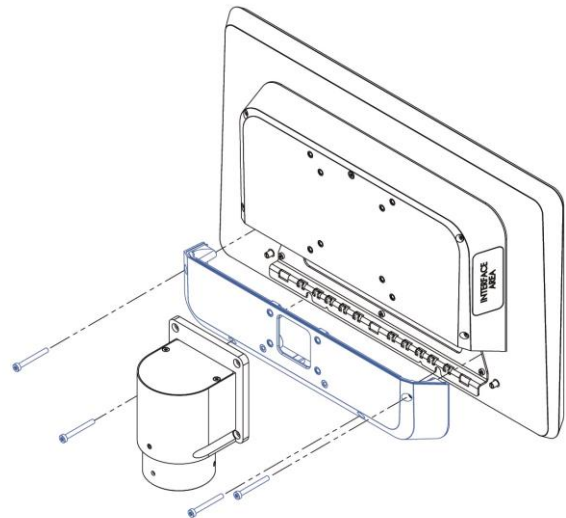

Illustration 31: Mounting VESA IP65 Step 1

### Step 2:

Fix the IP cover with the two lower screws to the Hanging in the device into the IP cover, connecting the cables and straighten up the device

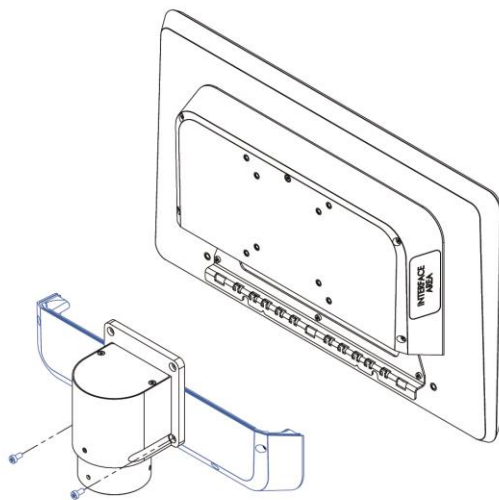

Illustration 32: Mounting VESA IP65 Step 2

### Step 3:

Fix the IP cover with the two lower screws to the Hanging in the device into the IP cover, connecting the cables and straighten up the device

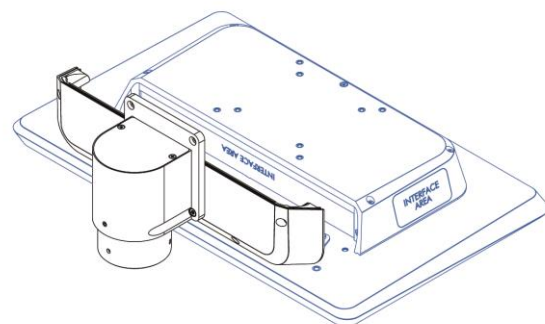
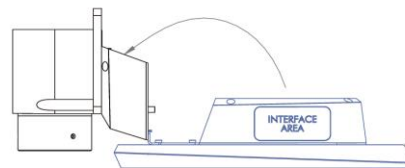
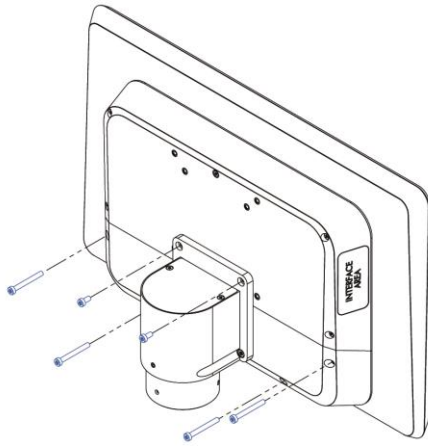

Illustration 33: Mounting VESA IP65 Step 3

# Instruction Manual: Touch Industrial PC

**Step 4:**

Hold up the device and tighten the screws



*Illustration 34: Mounting VESA IP65 Step 4*

**Final situation:**

Device is mounted to the mounting arm

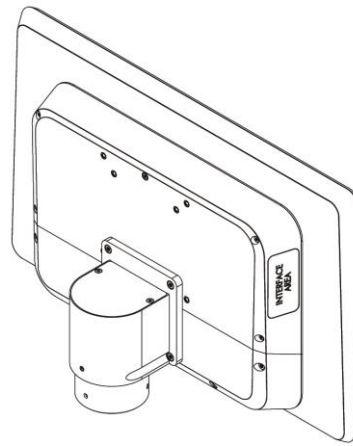

*Illustration 35: Mounting VESA IP65 final situation*

# Instruction Manual: Touch Industrial PC

## 4.5 Mounting Front Panel

<b>NOTICE</b>	
	<p><b>Seal does not close</b></p> <p>Moisture penetration into the device</p> <ul style="list-style-type: none"> <li>➤ Tighten the screws with a defined torque</li> </ul>

**Step 1:**

Install the front panel into the cutout

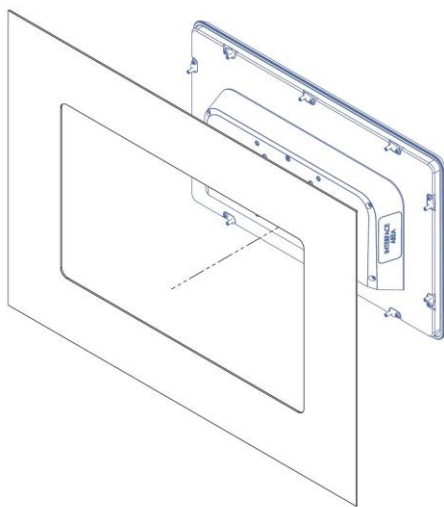

*Illustration 36: Mounting Front Panel Step 1*

**Step 2:**

The fastening clamps must lie entirely behind the mounting plate

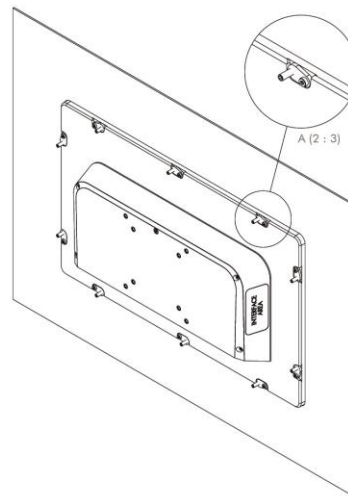

*Illustration 37: Mounting Front Panel Step 2*

**Step 3:**

Turn the fastening clamps outwards and tighten them with a torque of at least 1Nm

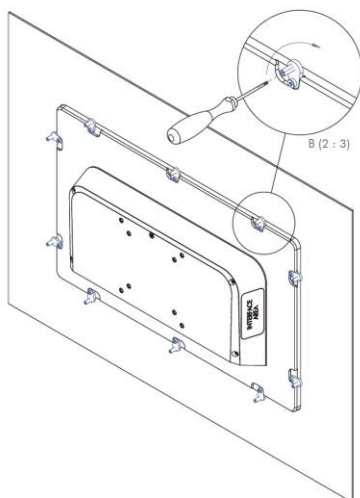

*Illustration 38: Mounting Front Panel Step 3*

# Instruction Manual: Touch Industrial PC

## 4.6 Mounting Open Frame

### Step 1:

Install the Open Frame Panel into the cutout

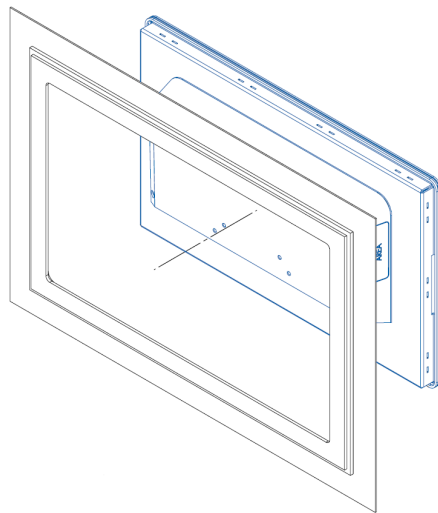

Illustration 39: Mounting Open Frame Step 1

### Step 2:

- 1 - Lightly screw the grub screw into the mounting bracket
- 2 - Insert the mounting bracket into the slots
- 3 - Engage the mounting bracket to one side

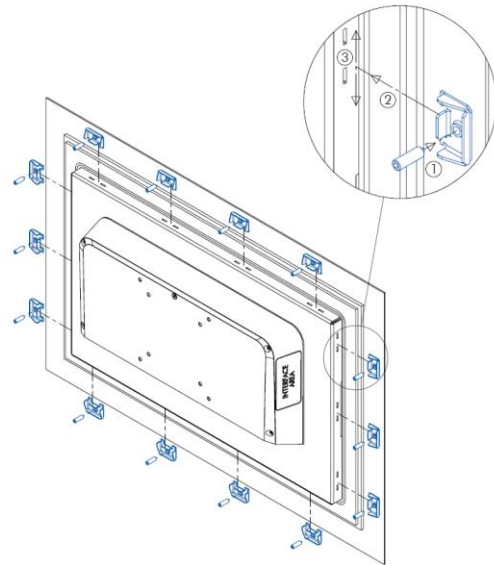

Illustration 40: Mounting Open Frame Step 2

### Schritt 3:

Tighten grub screw with a torque of min. 1 Nm

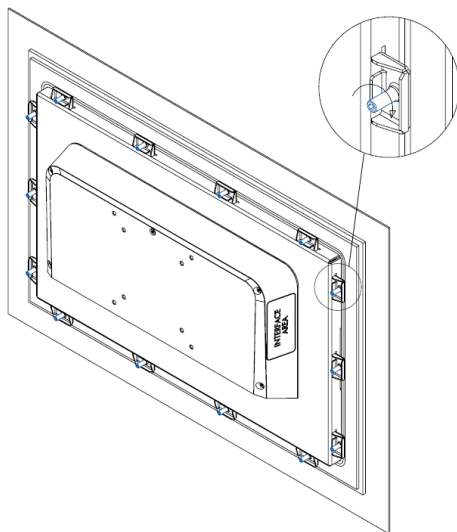

Illustration 41: Mounting Open Frame Step 3



# Instruction Manual: Touch Industrial PC

## 4.7 Faceplate

The faceplate can be extended at positions P1 to P8 using extension boards with switching elements of Schlegel. The steps for the expansion are described below.

The maximum number of the operating elements to be expanded is determined by the size of the device.

Size of the display	Maximum number of the operating elements
13.3"	4
15.6"	6
18.5"	8
21.5"	8
24"	8

### 4.7.1 Dismounting faceplate

**Step 1:**

Loosen the screws marked in blue on the back of the device.

**Step 2:**

Remove the faceplate carefully.

**Step 3:**

If cables are plugged into the faceplate, unplug them.

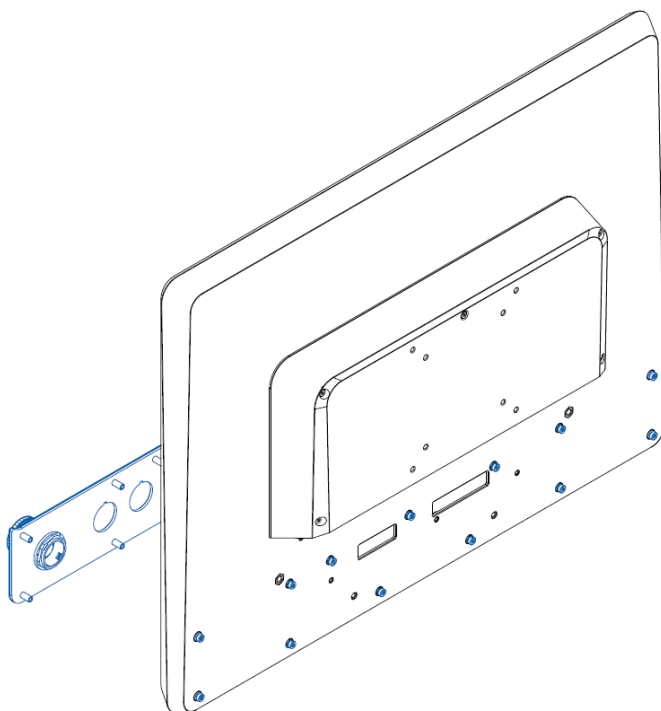

*Illustration 42: Disassembly faceplate*

# Instruction Manual: Touch Industrial PC

## 4.7.2 Adjusting the faceplate

At the positions where another control element is to be installed, the faceplate must be opened at the predefined points. The cut-out for the control element must be exactly as large as the faceplate specifies.

It is your own responsibility to decide how the adjustment is to be made. Attention must be paid to your own safety and risk of injury.

The control elements must be mounted on the faceplate.

**Notice:**

The control elements used must comply with the Schlegel Shortron ® base-plate mounting series.

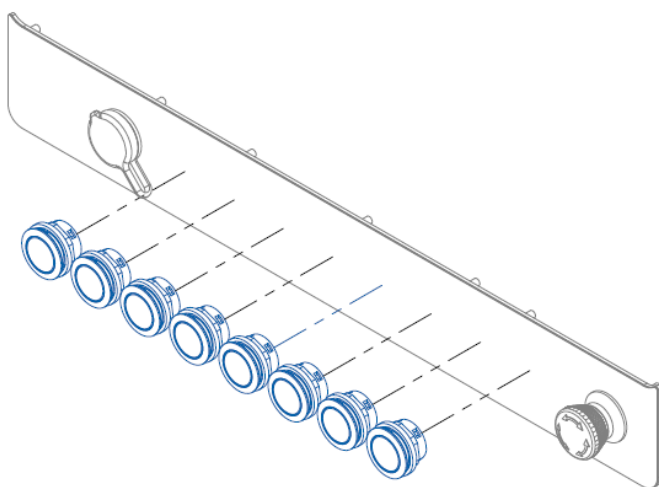

*Illustration 43: Positions of the control elements*

# Instruction Manual: Touch Industrial PC

## 4.7.3 Pushbutton boards

**Notice:**

If the pushbutton board for the control element to be expanded already exists, the following steps are not necessary.

**Step 1:**

Fasten the pushbutton board using the correct number of screws.

**Step 2:**

Plug the cable into the pushbutton board.

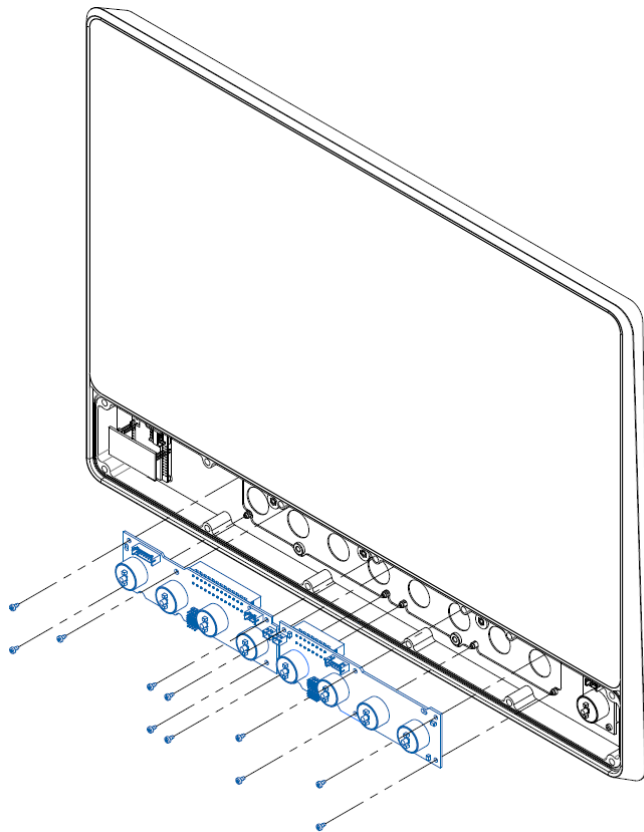

*Illustration 44: Mounting pushbutton board*

## 4.7.4 Mounting faceplate

After the extension has been completed, the faceplate is refitted.

**Step 1:**

If cables have been unplugged from the faceplate, plug them back in.

**Step 2:**

Attach the faceplate.

<b>NOTICE</b>	
	<p><b>Pinched cables</b></p> <p>Malfunction of the control elements</p> <ul style="list-style-type: none"> <li>➤ Cables must not be pinched</li> </ul>

## Instruction Manual: Touch Industrial PC

### **⚠ DANGER**



#### **Incorrect mounting of the emergency stop**

The function of the emergency stop is disturbed

- After each opening of the faceplate and before restarting the machine, a functional test of the emergency stop must be carried out.

#### **Step 3:**

Screw in all screws on the back.

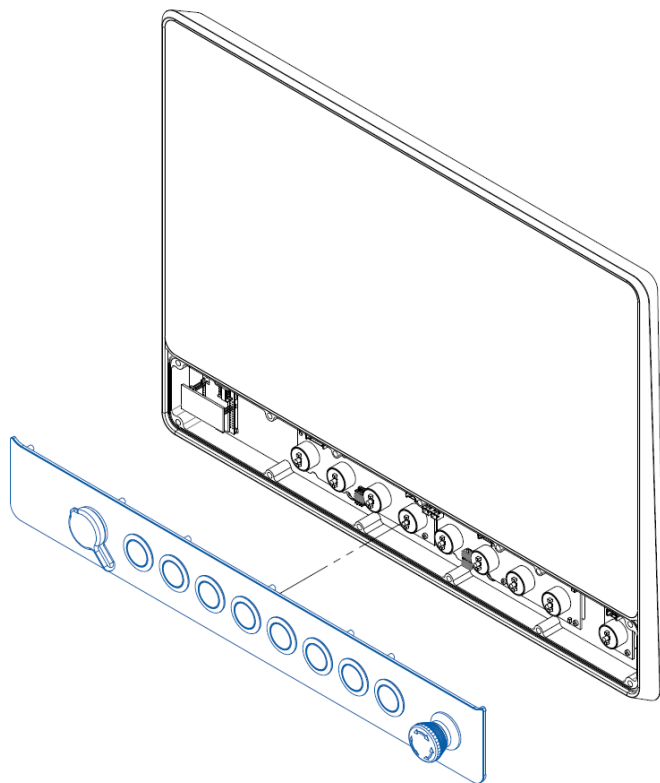

*Illustration 45: Mounting faceplate*

# Instruction Manual: Touch Industrial PC

## 5 Commissioning

To put the device into operation, connect the power supply to the unit.

The device starts.

Further steps for commissioning are not necessary.

### 5.1 Function of the power button

If the device has a power button, it behaves according to the following standard.

When the device is plugged into the power supply, the device boots up without having to press the power button.

If the power button is pressed while the device is running, the device shuts down.

If the power button is pressed while the device is not running, the device starts up. The power supply must be present at the device.

#### Notice:

A different behaviour may occur if the device does not have the standard configuration.

### 5.2 Unusual situations

Under certain circumstances, the unit may behave in an unusual way. These are listed below.

#### 5.2.1 Undefined state during start-up process

##### Description of error:

The device does not start completely, does not display anything.

##### Description:

There are two reasons why the errors may occur. These can both occur together or separately. The CPU board needs a stable power supply above 9.6 VDC in the first milliseconds of the start-up process. If the voltage rises too slowly during start-up, or falls again below 4.5 VDC, an undefined condition occurs. The delay is generated by an electronic fuse, for example. The voltage drop can occur when several components in the same circuit are started simultaneously.

##### Affected CPU boards:

- Argon: Intel® Celeron™ N3350 1.1 GHz

##### Solution:

If the device does not have a UPS, it can simply be restarted.

If a UPS is installed in the device, it stores the undefined state of the CPU board until it is completely discharged. This can take from a few minutes to several hours. The device must be disconnected from the power supply to discharge the UPS. After complete discharge, the device can be reconnected to the power supply and restarted.

In the above example, it may help to optimise the starting process of the power supply unit or the electronic fuse. If this does not work, a timer can be used as a further measure, which delays the start of the device by a few seconds.

# Instruction Manual: Touch Industrial PC

## 5.2.2 Sluggish touch behavior

### Description of error:

The touch's functionality is affected. The touch only triggers irregularly and behaves sluggishly.

### Description:

This behavior can be caused by the power supply if there is no conductive connection between GND of the power supply side and FE of the device side.

### Affected CPU boards:

- Argon: Intel® Celeron™ N3350 1.1 GHz
- Titanium: Intel® Celeron™ 3965U 2.2 GHz
- Titanium: Intel® Core™ i3-7100U 2.4 GHz
- Titanium: Intel® Core™ i5-7300U 2.6 GHz
- Titanium: Intel® Core™ i7-7600U 2.8 GHz

### Solution:

A power supply unit must be used with a conductive connection between GND of the power supply side and FE of the device side. Christ provides these power supply units.

# Instruction Manual: Touch Industrial PC

## 6 Accessories and Spare Parts

The accessories listed here have been checked by Christ and are compatible with the products. The following accessories are available:

### 6.1 Power supply

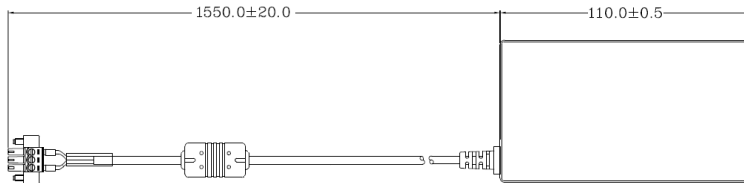

<b>Input Voltage</b>	90 - 264 VAC
<b>Input Current</b>	max. 1 A
<b>Input Frequency</b>	47 - 63 Hz
<b>Consumption with unloaded output</b>	max. 0.075 W
<b>Output Voltage</b>	24 VDC
<b>Output Current</b>	max. 2.5 A
<b>Temperature Range Operation</b>	0 - 70°C
<b>Humidity Operation</b>	20 - 80% RH non condensing

Table 34: Power supply

### 6.2 Stand

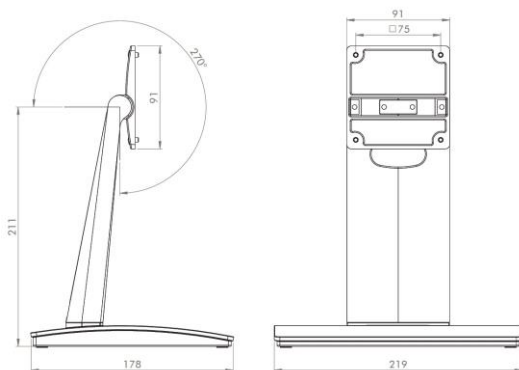

Illustration 46: Stand large

<b>VESA75 Stand large</b>
<b>Height 210 mm</b>
<b>Setting angle 0 - 99°</b>
<b>12.1" - 24"</b>

Table 35: Stand large

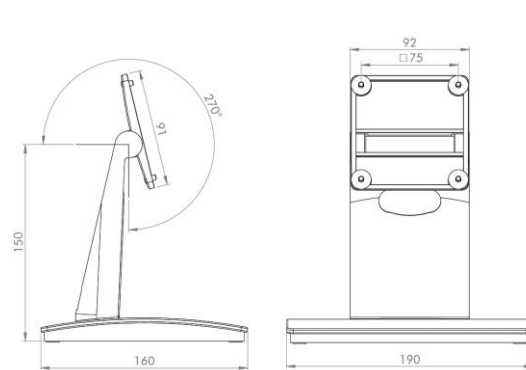

Illustration 47: Stand small

<b>VESA75 Stand small</b>
<b>Height 150 mm</b>
<b>Setting angle 0 - 81°</b>
<b>7" - 10.4"</b>

Table 36: Stand small

# Instruction Manual: Touch Industrial PC

## 7 Software

The Software chapter describes settings and functions that may be required to use the device.

The x86 architecture has a BIOS (Basic Input Output System) for the basic settings of the system. This is not present in the ARM architectures. Here, updates are performed with **CURT** (Christ Update and Recovery Tool).

### 7.1 BIOS Basic Settings

AMI BIOS ROM has built-in settings program that allows users to make basic settings. This information is stored in a battery supported CMOS RAM, so it remains stored even when there is no power supply.

Accessing the BIOS works by pressing the "Del" key several times while the device is booting.

The following tabs in the BIOS enable various settings.

<b>Main</b>	Set date
<b>Advanced</b>	Make advanced BIOS settings like: COM, ACPI, etc.
<b>Chipset</b>	Enter host bridge parameters
<b>Security</b>	Set administrator password
<b>Boot</b>	Set Boot Option
<b>Save &amp; Exit</b>	Save the settings made and initiate a restart. (Also possible with the F4 key on the keyboard)

Table 37: BIOS

Pressing F3 and confirming the query "Load Optimized Defaults?" with "Yes" restores the delivery state.

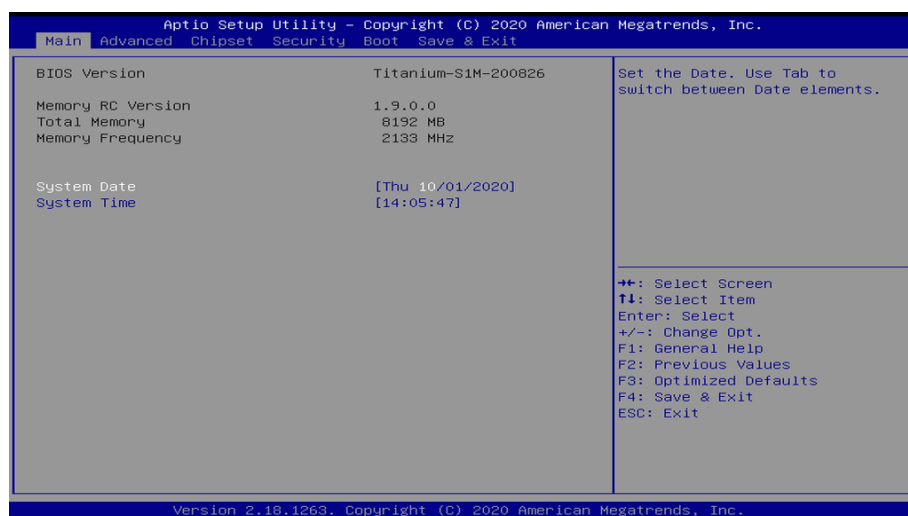

Illustration 48: BIOS



# Instruction Manual: Touch Industrial PC

## 7.1.1 Set display resolution

### Set Display Chanel and Resolution

#### Argon / Titanium

The following settings can be made in the BIOS:

1. Select "Advanced" tab
2. Select "LVDS Configuration"
3. Select "LVDS Chanel Type" (Set "Dual" for Full HD displays)
4. Select "LCD Panel Type"
5. Set resolution
6. Save with keystroke "F4" (confirmation with "Yes")

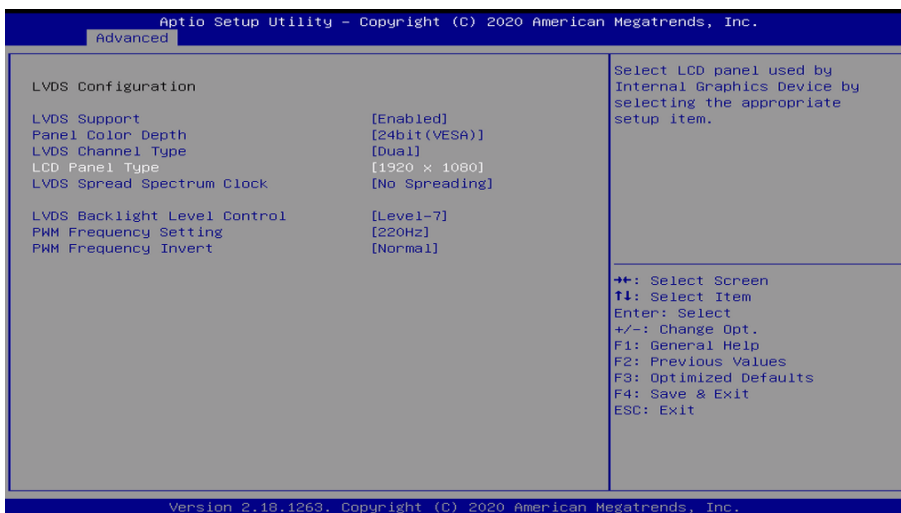

Illustration 49: BIOS Display Resolution

## 7.1.2 COM Port configuration

### COM Port configuration

#### Argon

In order for RS-232, RS-422 and RS-485 to be recognized on the COM port, the following settings must be made in the BIOS:

1. Select "Advanced" tab
2. Select "F81804 Super IO Configuration"
3. Select "Serial Port1 Configuration"
4. Make setting in "Device Mode" (RS-422 / RS-485 / RS-232)
5. Save with keystroke "F4" (confirmation with "Yes")

### COM Port configuration

#### Titanium

In order for RS-232, RS-422 and RS-485 to be recognized on the COM port, the following settings must be made in the BIOS:

## Instruction Manual: Touch Industrial PC

1. Select "Advanced" tab
2. Select "F81804 Super IO Configuration"
3. Select "Serial Port1 Configuration"
4. Under "F81846 SERIAL PORT1 MODE SELECT" select the mode (RS232, RS422, RS485)
5. If RS422 or RS485 mode has been selected, settings can be made for "RS422/RS485 Termination" or "RTS Auto Flow Control"
6. Save with keystroke "F4" (confirmation with "Yes")

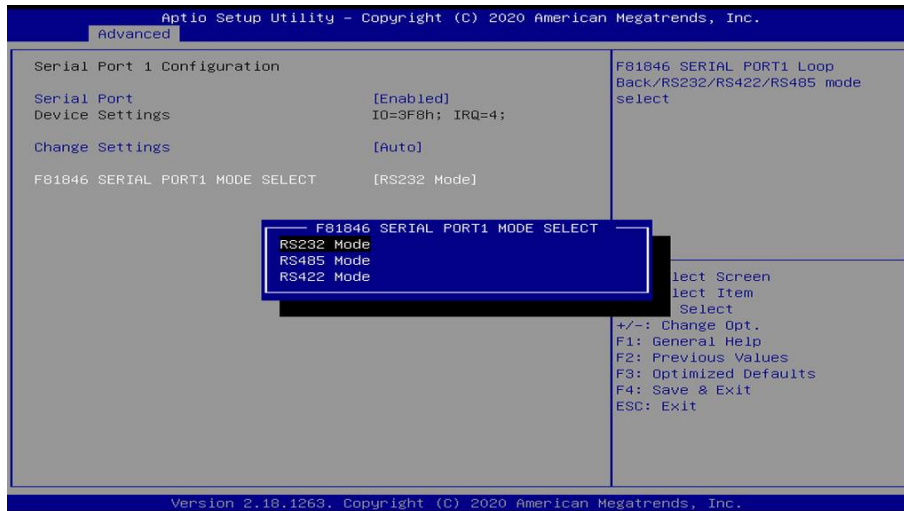

Illustration 50: BIOS COM Port Titanium

### 7.1.3 Set Boot Priority

#### Set Boot Priority

##### Argon / Titanium

If you want to boot from a USB device, the following settings must be made in the BIOS:

1. Select "Boot" tab
2. Select "Boot mode select" "UEFI"
3. Open the "Boot Option #1" by pressing the "Enter" key
4. Select USB device with "Enter"
5. Save with keystroke "F4" (confirmation with "Yes")

# Instruction Manual: Touch Industrial PC

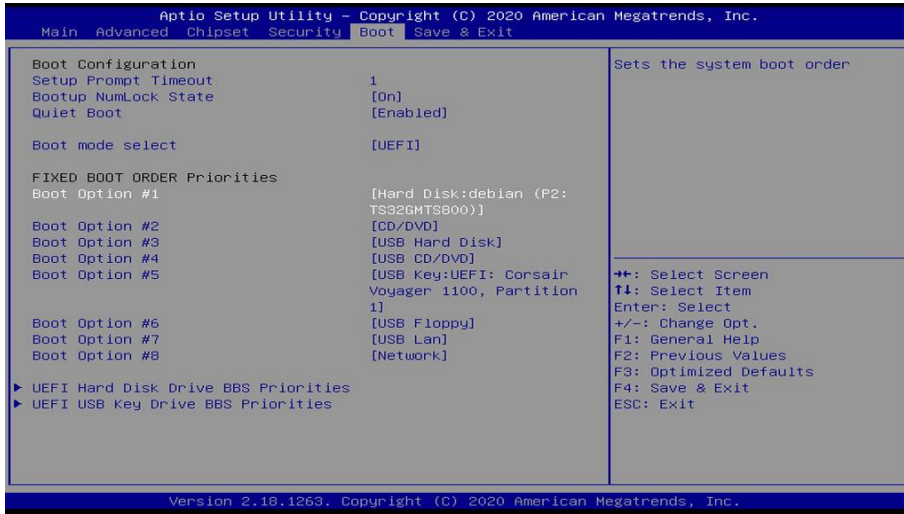

Illustration 51: BIOS Boot Priority

# Instruction Manual: Touch Industrial PC

## 7.2 BIOS Update

### 7.2.1 Preparation

Copy the AMI BIOS update files to a USB stick

You can obtain the required files from Christ Electronic Systems. These are the same for Argon and Titanium.

- efi
- flash.nsh
- fparts.txt
- Fpt.efi
- Titanium-200826a-S1M.bin (This .bin is only an example, the file can also be named differently)

### 7.2.2 Perform Update

Insert the bootable USB stick with the required files into the device.

Set the USB stick to Hard Disk Boot Priority in the BIOS. You can read about the procedure under [Boot Priority](#).

The EFI Update Script is automatically detected on the USB stick and starts the update process.

#### Further procedure Argon

- Confirm the question: "Enter 'q' to quit, any other key to continue:" with Enter.

```

If you don't want to update, press 'q', else press any key to update!
=====
Enter 'q' to quit, any other key to continue: _
    
```

*Illustration 52: Argon BIOS Update*

- Confirm the question "Do you want to continue? Y/<N> or q to quit:" with "y"
- The update is executed
- The message "FPT Operation Successful" indicates successful completion

```

FPT Operation Successful.
Done! Please turn off the system
    
```

*Illustration 53: Argon BIOS Update successful*

- Disconnect the power supply
- Restore the power supply and enter the BIOS again (do not reboot)
- Press the F3 key to confirm the question "Load Optimized Defaults" with "Yes"
- Press the F4 key to save and exit

#### Further procedure Titanium

Confirm the question: "Enter 'q' to quit, any other key to continue:" with Enter.

## Instruction Manual: Touch Industrial PC

```
If you don't want to update, press 'q', else press any key to update!
=====
Enter 'q' to quit, any other key to continue: _
```

*Illustration 54: Titanium BIOS Update*

- The update is executed
- The message "FPT Operation Successful" indicates successful completion

```
FPT Operation Successful.
Done! Please turn off the system
```

*Illustration 55: Titanium BIOS Update successful*

- Disconnect the power supply
- Restore the power supply and enter the BIOS again (do not reboot)
- Press the F3 key to confirm the question "Load Optimized Defaults" with "Yes"
- Press the F4 key to save and exit

# Instruction Manual: Touch Industrial PC

## 7.3 OBS Client

### 7.3.1 Activating the OBS Client

The OBS client is disabled by default.

To enable the OBS client, perform the following steps:

1. Launch Task Manager
2. Open "Startup" tab
3. Select "Hardware Monitor Utility for IBASE" and activate it by clicking on "Enable"

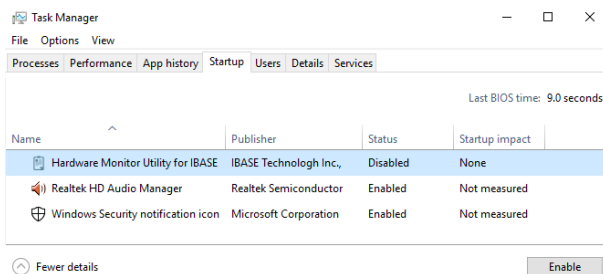

Illustration 56: Task Manager - enable OBS Client

4. Perform a restart of the device

### 7.3.2 Functions of the OBS Client

To start the OBS client, expand the taskbar and click on the key icon.



Illustration 57: Start OBS Client

These functions are provided by the OBS Client:

#### System Information

The System Information provides information about the processor and the operating system.

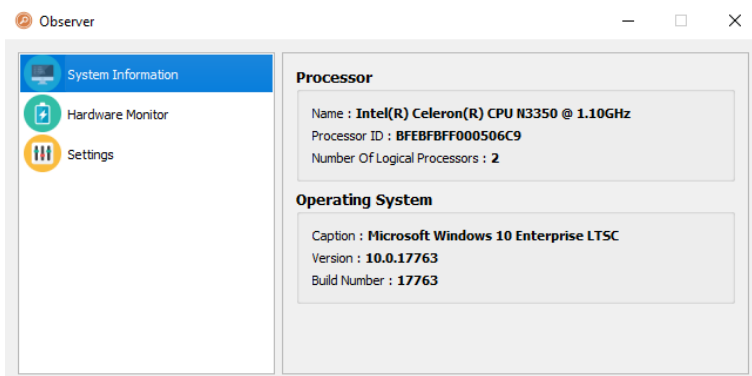

Illustration 58: OBS Client System Information

# Instruction Manual: Touch Industrial PC

## Hardware Monitor

The Hardware Monitor category indicates the approximate temperatures of the processor and peripherals.

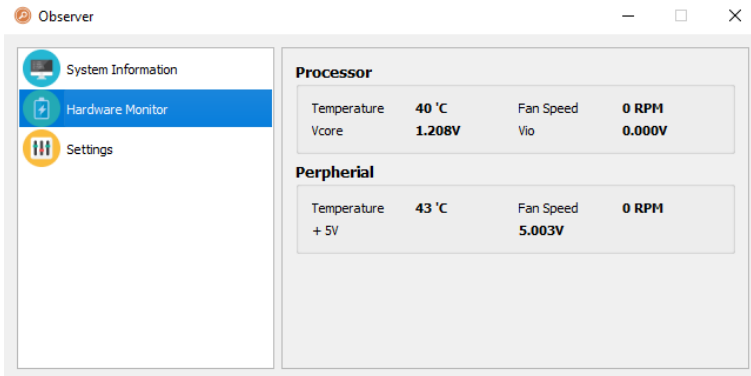

Illustration 59: OBS Client Hardware Monitor

## Settings

Various settings can be made in the Settings area.

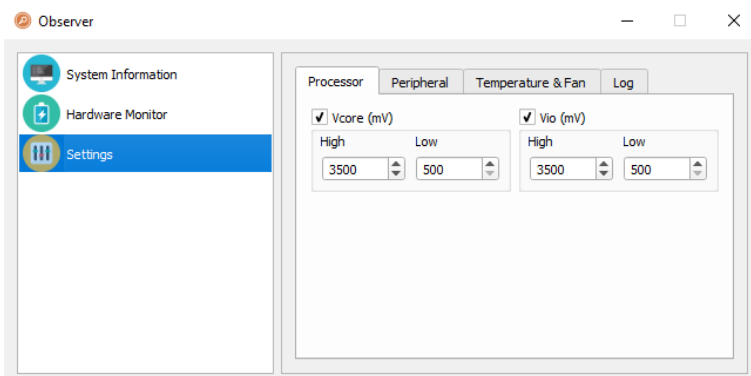

Illustration 60: OBS Client Settings

## 7.4 Redo Backup and Recovery

The instructions for Christ Redo Backup and Recovery can be found in the Download section of the Christ website: [Downloads](#)

## 7.5 Enhanced Write Filter EWF

Instructions on how to set EWF and UWF filters can be found in the download section of the Christ website: [Downloads](#)

# Instruction Manual: Touch Industrial PC

## 8 Maintenance

The following chapter describes maintenance measures that can be performed by a qualified end user.

<b>NOTICE</b>	
	<p><b>Seals attacked, damage to the housing</b></p> <p>Loss of IP protection class</p> <ul style="list-style-type: none"> <li>➤ There must be no permanent exposure to substances containing large amounts of oils or fats.</li> </ul>

### 8.1 Cleaning

<b>⚠ DANGER</b>	
	<p><b>Triggering unintended functions</b></p> <p>Loss of control of the plant / machine / device</p> <ul style="list-style-type: none"> <li>➤ The unit may only be cleaned when it is switched off or unplugged.</li> </ul>

To clean the device, use a soft cloth moistened with detergent solution or screen cleaner. The cleaning agent must not be applied directly to the device. Under no circumstances may aggressive solvents, chemicals or scouring agents be used.

### 8.2 Maintenance

It does not require any maintenance on the part of the user.



# Instruction Manual: Touch Industrial PC

## 9 Technical Data

This chapter summarizes the technical data.

### 9.1 Mechanical Specifications

The weight specifications are maximum guideline values. They are given in the unit kilogram [kg].

	VESA	VESA Automation	Front Panel	Open Frame
7"	1.4	--	1.4	--
10.1"	2.3	--	2.3	1.9
10.4"	2.3	--	2.3	tbd
12.1"	2.7	--	2.7	tbd
13.3"	2.8	tbd	2.7	tbd
15"	3.7	--	3.7	tbd
15.6"	3.8	4.5	3.8	tbd
18.5"	4.9	5.8	4.7	tbd
21.5"	5.9	7.0	5.7	tbd
24"	6.5	7.6	6.3	tbd

Table 38: Weight

For IP65 rear, the above weight specification must be supplemented by the corresponding value:

VESA	0.5 kg
VESA Automation	0.6 kg

Table 39: IP65 Weight

### 9.2 Electrical Specifications

Supply Voltage	9,6 VDC ... 28,8 VDC
Power Consumption	see table Power Consumption
Inrush Current (load-independent)	max. 70A for 80 $\mu$ s (Used power supply: FSP060-DAAN3)
External Power Supply	SELV
Earthing	Functional Earthing (Cable cross-section has to be identical to the supply lines)
Battery Lifetime	4 years (constantly turned off)

Table 40: Electrical Specifications

# Instruction Manual: Touch Industrial PC

## 9.3 Power Consumption

Display Size	Power Consumption
7"	up to 55 W
10.1"	up to 60 W
10.4"	up to 55 W
12.1"	up to 65 W
13.3"	up to 70 W
15"	up to 65 W
15.6"	up to 70 W
18.5"	up to 80 W
21.5"	up to 75 W
24"	up to 75 W

Table 41: Power Consumption

NOTICE	
	<p><b>Specifications are maximum values</b></p> <p>Peripheral devices are considered (e.g. 1 x USB 2.0 equals 2,5 W)</p> <ul style="list-style-type: none"> <li>➤ Provide sufficient power</li> </ul>

## 9.4 Electromagnetic Compatibility

Emitted Interference	EN55032 Class A
Immunity of supply line DC	±2 kV according to IEC 61000-4-4; EFT ± 0,5 kV according to IEC 61000-4-5; Surge asymmetrical
Immunity of signal lines	±1 kV according to IEC 61000-4-4; EFT
ESD	± 4 kV Contact discharge according to EN61000-4-2 ± 8 kV Air discharge according to EN 61000-4-2
Immunity of conducted emission	3 V 150 kHz – 80 MHz, 80% AM nach IEC 61000-4-6
Immunity of high-frequency radiation	3 V/m 80 MHz – 1 GHz, 80% AM nach IEC 61000-4-3 3 V/m 1 GHz – 6 GHz, 80% AM nach IEC 61000-4-3

Table 42: Electromagnetic Compatibility

# Instruction Manual: Touch Industrial PC

## 9.5 Environmental Conditions

Ambient Temperature (Standard Conditions)	0 ~ 50 °C
Ambient Temperature (Different Conditions)	0 ~ 40 °C (see device-specific datasheet)
Storage Temperature	-10 ~ 70 °C
Humidity	5 ~ 80 % (non condensing)
Protection Class (Standard Conditions)	IP65 (IP20 rear)
Protection Class (Different Conditions)	IP65 (see device-specific datasheet)
Shock Resistance (Sinusoidal Vibration)	EN 60068-2-6: 5...9 Hz at individual amplitudes of 1,5 mm 9...200 Hz constant acceleration: 30 m/s <sup>2</sup> X, Y, Z orientations with 10 cycles (approx. 10 min)
Shock Resistance (Shock)	EN 60068-2-27 70 m/s <sup>2</sup> , 3 times in X, Y, Z - orientations
Transportation and Storage	Suitable packing increases shock resistance
max. Installation Altitude	2000 m
Cooling	Natural Air Convection

Table 43: Environmental Conditions

<b>NOTICE</b>	
	<p><b>Insufficient air supply to the device</b></p> <p>Overheating</p> <ul style="list-style-type: none"> <li>➤ Never cover the device completely or operate it in a small, unventilated housing</li> </ul>

## 9.6 Temperature test

The values for ambient temperature and humidity were determined under worst-case conditions. The maximum workload of the system was achieved by the BurnInTest from PassMark Software Pty Ltd.

The test ran under 100 % utilisation of:

- CPU
- RAM
- 2D and 3D Graphic (x86 only)
- Brightness of the display

## 9.7 IP Protection Class

The protection class only can be guaranteed under the following conditions:

# Instruction Manual: Touch Industrial PC

- The device is installed correctly
- All components and covers of the interfaces are assembled
- Compliance with all environmental conditions

## 9.8 Display Specifications

<b>Color Depth</b>	8 bit
<b>Lifetime</b>	min. 50,000 h
<b>Viewing Angle (right/left/up/down)</b>	min. 85°/85°/85°/85°
<b>Backlight</b>	LED
<b>Touch Technology</b>	PCAP

Table 44: Display Specifications

<b>NOTICE</b>	
	<p><b>Pixel Errors</b></p> <p>Due to the manufacturing process, displays may contain faulty pixels (pixel errors), which do not constitute a claim or warranty within the limits described below.</p>

The international standard ISO 9241-307:2009 defines, on an international level, the maximum permissible pixel errors in an LC-display. This standard describes different error types, in consideration of different pixel error classes.

There are the following pixel error classes, each with three different error types:

<b>Maximum acceptable errors per 1 Mio. pixels according to ISO 9241-307:2009</b>				
error class	error type 1 pixel constantly illuminated	error type 2 pixel constantly dark	error type 3 subpixel constantly illuminated	error type 4 subpixel constantly dark
0	0	0	0	0
I	1	1	n = 0 to 2 2 - n	2 x n + 1
II	2	2	n = 0 to 5 5 - n	2 x n
III	5	15	max. 50	max. 50
IV	50	150	max. 150	max. 150

Why this classification of errors?

Each pixel of a display contains three subpixels which have the basic colors red, green and blue. The combination makes it possible to show a wide spectrum of colors.

Considering for example the display solution of 1280 x 800 pixels, thereof a total of 1,024,000 pixels or 3,072,000 subpixels are embedded in the display area. This means, the display holds 3,072,000 single transistors at an area of 261.1 mm by 163.2 mm.

## Instruction Manual: Touch Industrial PC

These figures make it clear that it is not possible to specifically produce defect-free displays even by today's manufacturing standards.

Christ Electronic Systems GmbH therefore adapts to the corresponding requirements of most international manufacturers. The displays must always comply with error class II. If the permissible number of errors of the pixel error class II is not exceeded, there is also no complaintable "failure" of the display.

Referring to the calculation, the following errors can occur in the display:

- Max. 2 constantly illuminated and 2 constantly dark pixels
- Max. 5 constantly illuminated or 10 constantly dark subpixel

### Avoid burn-in on displays

<b>NOTICE</b>	
	<p><b>Images that do not change</b></p> <p>"Image shadows", "ghost images" arise</p> <p>➤ Changing displayed images, screen saver, energy-saving mode</p>

With LC displays, so-called "ghost images" or "image shadows" can occur under certain circumstances. These are images that remain from the previous image and are felt to be "burnt into" the display. These do not remain forever. If "image shadows" occur, the device should be switched off for a longer period of time so that the burnt-in image disappears.

To avoid "ghost images" or "image shadows", the following behaviour is recommended:

- Do not display still images over an extended period of time
- Change standing images at short intervals
- Switch off the unit or use the energy-saving mode when not in use
- Use the screen saver function

# Instruction Manual: Touch Industrial PC

## 10 Standards and Approvals

The device meets the following requirements.

### 10.1 CE Marking



The device has been tested in accordance with the applicable EU directives and the associated harmonized standards.

### 10.2 RoHS



The device complies with the requirement of the EU Directive RoHS 2011/65/EU.

### 10.3 Electromagnetic Compatibility

The device complies with the requirements of the EU Electromagnetic Compatibility Directive 2014/30/EU with the harmonized standards listed below:

EN 55032: 2015 Class A	Electromagnetic compatibility of multimedia equipment - Emission Requirements
EN 55035: 2017	Electromagnetic compatibility of multimedia equipment - Immunity requirements

### 10.4 Environmentally Appropriate Disposal

**The device must not be disposed of with domestic waste.**



The appliance complies with the requirement of the EU Directive WEEE 2012/19/EU, which is symbolised by the symbol with the crossed-out dustbin.

In order to enable environmentally friendly recycling, the various materials must be separated from one another.

Disposal must be carried out in accordance with the applicable legal regulations.

Component parts	Disposal
Enclosure	Metal Recycling
Electronic	Electronics Recycling
Paper / cardboard packaging	Paper / Cardboard boxes Recycling
Plastic packing materials	Plastics Recycling

# Instruction Manual: Touch Industrial PC

## 11 Technical Support

Despite the highest quality standards and detailed function tests of all our products, damage or failure can always occur in the daily handling of our equipment. The failure of a machine in production costs a lot of money. That is why the Christ company processes complaints as quickly as possible.

You can send the device to us without prior notice. All you need to do is fill out the [repair cover letter](#) and enclose it with the touch panel or IPC so that the service department can start the repair quickly. When the device arrives, it goes through a defined process that clearly documents all processes and makes the respective status traceable. As soon as your panel or IPC is registered in our system, you will receive a confirmation of receipt so that you can also get a precise overview.

Technical Support can be contacted as follows:

Service, Repair and Technical Support

Phone: +49 8331 8371-500

Fax: +49 8331 8371-497

E-Mail: [service@christ-es.de](mailto:service@christ-es.de)

Or directly via the Homepage.

[Christ Service](#)

### 11.1 Device Seal

A device seal is affixed to every Christ device in order to prove whether the device has been opened by a third party. In case of a defect, please do not open the device, but contact our service department. They will discuss the further procedure with you.

# Touch Industrial PC

## Instruction Manual

### Index of Illustration

Illustration 1: VESA Front	9
Illustration 2: VESA Rear	9
Illustration 3: VESA IP65 Front	9
Illustration 4: VESA IP65 Rear	9
Illustration 5: Dimensions VESA	10
Illustration 6: Dimensions VESA Rear	10
Illustration 7: VESA IP65 Cover	11
Illustration 8: VESA Automation Front	12
Illustration 9: VESA Automation Rear	12
Illustration 10: VESA Automation IP65 Front	13
Illustration 11: VESA Automation IP65 Rear	13
Illustration 12: Dimensions VESA Automation	13
Illustration 13: Dimensions VESA Automation Rear	14
Illustration 14: VESA Automation IP65 Cover	14
Illustration 15: Front Panel Front	20
Illustration 16: Front Panel Rear	20
Illustration 17: Dimensions Front Panel	20
Illustration 18: Dimensions Front Panel Rear	21
Illustration 19: Dimensions Front Panel Cutout	21
Illustration 20: Open Frame Front	22
Illustration 21: Open Frame Rear	22
Illustration 22: Dimensions Open Frame	23
Illustration 23: Dimensions Open Frame Rear	23
Illustration 24: Dimensions Open Frame Cutout Counterplate	24
Illustration 25: Dimensions Open Frame Cutout Front- and Spacerplate	24
Illustration 26: Installation Open Frame Cutout	25
Illustration 27: Connection of the power supply	35
Illustration 28: Mounting VESA Step 1	36
Illustration 29: Mounting VESA final situation	36
Illustration 30: Mounting VESA IP65 initial situation	37
Illustration 31: Mounting VESA IP65 Step 1	37
Illustration 32: Mounting VESA IP65 Step 2	37
Illustration 33: Mounting VESA IP65 Step 3	37
Illustration 34: Mounting VESA IP65 Step 4	38
Illustration 35: Mounting VESA IP65 final situation	38
Illustration 36: Mounting Front Panel Step 1	39
Illustration 37: Mounting Front Panel Step 2	39
Illustration 38: Mounting Front Panel Step 3	39
Illustration 39: Mounting Open Frame Step 1	40
Illustration 40: Mounting Open Frame Step 2	40



# Touch Industrial PC

## Instruction Manual

Illustration 41: Mounting Open Frame Step 3	40
Illustration 42: Disassembly faceplate	41
Illustration 43: Positions of the control elements	42
Illustration 44: Mounting pushbutton board	43
Illustration 45: Mounting faceplate	44
Illustration 46: Stand large	47
Illustration 47: Stand small	47
Illustration 48: BIOS	48
Illustration 49: BIOS Display Resolution	49
Illustration 50: BIOS COM Port Titanium	50
Illustration 51: BIOS Boot Priority	51
Illustration 52: Argon BIOS Update	52
Illustration 53: Argon BIOS Update successful	52
Illustration 54: Titanium BIOS Update	53
Illustration 55: Titanium BIOS Update successful	53
Illustration 56: Task Manager - enable OBS Client	54
Illustration 57: Start OBS Client	54
Illustration 58: OBS Client System Information	54
Illustration 59: OBS Client Hardware Monitor	55
Illustration 60: OBS Client Settings	55

# Touch Industrial PC

## Instruction Manual

### Index of Tables

Table 1: History	5
Table 2: System overview Argon	8
Table 3: System overview Titanium	8
Table 4: VESA Front and VESA Rear	9
Table 5: VESA IP65 Front and VESA IP65 Rear	9
Table 6: Dimensions VESA	11
Table 7: VESA Automation Front and VESA Automation Rear	12
Table 8: VESA Automation IP65 Front and VESA Automation IP65 Rear	13
Table 9: Dimensions VESA Automation	14
Table 10: Front Panel Front und Front Panel Rear	20
Table 11: Dimensions Front Panel	21
Table 12: Dimensions Front Panel Cutout	22
Table 13: Open Frame Front und Open Frame Rear	22
Table 14: Dimensions Open Frame	24
Table 15: Dimensions Open Frame Cutout	24
Table 16: Pinout Supply Connector screwable	26
Table 17: Pinout USB 2.0	26
Table 18: Pinout USB 3.0	27
Table 19: Pinout Ethernet 10BaseT 100BaseT	27
Table 20: Pinout Ethernet Gigabit	27
Table 21: Pinout WLAN	28
Table 22: Pinout Serial Connector Titanium	28
Table 23: Pinout Serial Connector Celeron N3350 Argon	29
Table 24: Pinout UPS	29
Table 25: Pinout Display Port	30
Table 26: Pinning Phoenix DMCV 1,5/13-G1F-3,5-LR P20THR	31
Table 27: Pinning Phoenix DMCV 1,5/8-G1F-3,5-LR P20THR	32
Table 28: UPS buffer duration	32
Table 29: Add On Ethernet and USB	33
Table 30: Wireless LAN	33
Table 31: Add On side USB 2.0	33
Table 32: Add On side USB 3.0	33
Table 33: Add On side Power Button	33
Table 34: Power supply	47
Table 35: Stand large	47
Table 36: Stand small	47
Table 37: BIOS	48
Table 38: Weight	57
Table 39: IP65 Weight	57
Table 40: Electrical Specifications	57

# Touch Industrial PC

## Instruction Manual

Table 41: Power Consumption	58
Table 42: Electromagnetic Compatibility	58
Table 43: Environmental Conditions	59
Table 44: Display Specifications	60